



TelQuest International

<https://www.telquestintl.com/>

973-808-4588

# Panasonic®

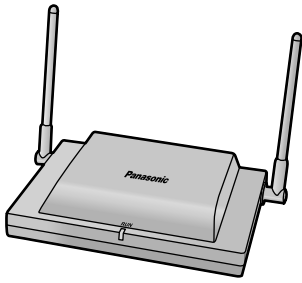

## Quick Installation Guide

### DECT 6.0 Cell Station Unit

---

Model No. **KX-T0155/  
KX-T0158/KX-TDA0156**

Thank you for purchasing a Panasonic DECT 6.0 Cell Station Unit.  
Please read this manual carefully before using this product and save this manual for future use.

# Important Information

## SAVE THESE INSTRUCTIONS

### Safety Notices

Please observe the safety notices in this manual in order to avoid danger to users or other people, and prevent damage to property.

The notices are classified as follows, according to the severity of injury or damage:

<b><u>WARNING</u></b>	This notice means that misuse could result in death or serious injury.
<b><u>CAUTION</u></b>	This notice means that misuse could result in injury or damage to property.

### **WARNING**

#### **SAFETY REQUIREMENTS**

- The product must only be installed and serviced by qualified service personnel. The product should be used as-is from the time of purchase; it should not be disassembled or modified. Disassembly or modification can cause a fire, electric shock, or damage to the product.
- Make sure that the wall that the unit will be attached to is strong enough to support the unit (approx. 310 g [11 oz]). If not, it is necessary for the wall to be reinforced.
- Only use the wall-mounting equipment (screws, washers, wall mounting plate) included with the unit.
- When this product is no longer in use, make sure to detach it from the wall.
- Do not connect or disconnect the telephone cord with wet hands.
- Disconnect the unit from the telephone cord, and contact the dealer if:
  - The unit is exposed to rain, water, or any other liquid.
  - The unit is dropped or damaged.
  - Internal components are exposed due to damage.
  - The unit does not operate properly.
  - Performance deteriorates.
- Disconnect the unit from the telephone cord if the unit emits smoke, an abnormal smell, or makes unusual noise. These conditions can cause fire or electric shock. Confirm that smoke has stopped and contact an authorized service center.
- Do not touch the unit, or telephone cord during a lightning storm.
- Do not allow anything to rest on the telephone cord. Do not locate this unit where the telephone cord may be stepped on or tripped on.

### **CAUTION**

#### **SAFETY REQUIREMENTS**

- The CS should be kept free of dust, moisture, high temperature (more than 40 °C [104 °F]), low temperature (less than 0 °C [32 °F]), and vibration, and should not be exposed to direct sunlight.
- The CS should not be placed outdoors (use indoors).
- The CS should not be placed near high-voltage equipment.
- The CS should not be placed on a metal object.
- When driving the screws into the wall, be careful to avoid touching any metal laths, wire laths or metal plates in the wall.
- To prevent malfunction, deformity, overheating, rust, and discoloration, do not install or place equipment in the following types of locations:

- Locations where air ventilation is poor.
- Locations that may be exposed to sulphurous gas, such as near hot springs.
- Near devices that emit heat, such as heaters.
- Near devices that emit electromagnetic noise, such as radios or televisions.
- Near devices that emit high-frequency noise, such as sewing machines or welders.
- Do not stretch or bend the cables. Also, do not allow anything to rest on the cables.
- Use cables that are fire-resistant or fireproof.
- The CS and the cables should never be placed near or over a radiator or other heat source.
- Do not bundle cables that are connected to the CS with the AC power cords of machines located nearby.
- Make sure the cables are securely fastened to the wall.
- Disconnect the telephone cord from the unit before cleaning. Clean the unit with a soft, dry cloth. Do not use liquid, aerosol cleaners, abrasive powders, or chemical agents to clean the unit.
- When left unused for a long period of time, disconnect the unit from the telephone cord.
- **Medical**—consult the manufacturer of any personal medical devices, such as pacemakers, to determine if they are adequately shielded from external RF (radio frequency) energy. (The unit operates in the frequency range of 1920 MHz to 1930 MHz, and the output peak power level is less than 0.12 W.) Do not use the unit in health care facilities if any regulations posted in the area instruct you not to do so. Hospitals or health care facilities may be using equipment that could be sensitive to external RF (radio frequency) energy.

### **Notice**

#### **SAFETY REQUIREMENTS**

- Before connecting the unit, confirm that the unit supports the intended operating environment.
- If the unit does not operate properly, disconnect the telephone cord, then connect again.
- The unit may not operate in the event of a power failure.
- Do not move the unit while it is in use.
- Satisfactory operation, interoperability, and compatibility cannot be guaranteed with all equipment connected to the unit, nor with all services provided by telecommunications providers over networks connected to the unit.

#### **SECURITY REQUIREMENTS**

- Privacy of communications may not be ensured when using the wireless systems.

## Additional Information

### F.C.C. REQUIREMENTS AND RELEVANT INFORMATION

#### **CAUTION**

Any changes or modifications not expressly approved by the party responsible for compliance could void the user's authority to operate this device.

#### **Note**

This equipment has been tested and found to comply with the limits for a Class B digital device, pursuant to Part 15 of the FCC Rules. These limits are designed to provide reasonable protection against harmful interference in a residential installation. This equipment generates, uses, and can radiate radio frequency energy and, if not installed and used in accordance with the instructions, may cause harmful interference to radio communications. However, there is no guarantee that interference will not occur in a particular installation. If this equipment does cause harmful interference to radio or television reception, which can be determined by turning the equipment off and on, the user is encouraged to try to correct the interference by one or more of the following measures:

- Reorient or relocate the receiving antenna.
- Increase the distance between the equipment and receiver.
- Connect the equipment to an outlet on a circuit different from that to which the receiver is connected.
- Consult the dealer or an experienced radio/TV technician for help.

Some wireless telephones operate at frequencies that may cause interference to nearby TVs and VCRs. To minimize or prevent such interference, the base of the wireless telephone should not be placed near or on top of a TV or VCR. If interference is experienced, move the wireless telephone further away from the TV or VCR. This will often reduce, or eliminate, interference.

#### **RF Exposure Warning:**

This product complies with FCC radiation exposure limits set forth for an uncontrolled environment. To comply with FCC RF exposure requirements, this product must be installed and operated in accordance with the provided instructions. The installed unit requires a minimum 20 cm (8 inches) of spacing between the antenna and a person's body (excluding hands, wrists and feet) during wireless modes of operation.

This transmitter must not be co-located or operated in conjunction with any other antennas or transmitters.

# Table of Contents

- 1 Overview .....6**
- 2 Procedure Overview .....10**
- 3 Site Planning .....12**
- 4 Before Site Survey .....16**
- 5 Site Survey .....21**
- 6 After Site Survey .....25**
- 7 Connecting a Cell Station to the PBX .....26**
- 8 Wall Mounting .....42**
- 9 Troubleshooting .....45**

# 1 Overview

## Names and Locations

KX-T0155/KX-TDA0156

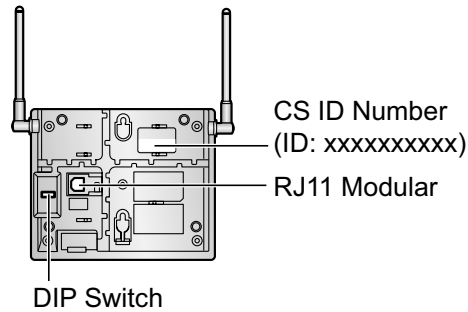
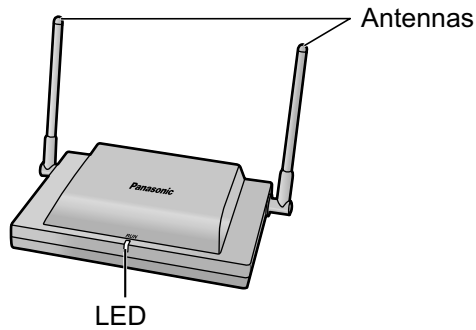

KX-T0158

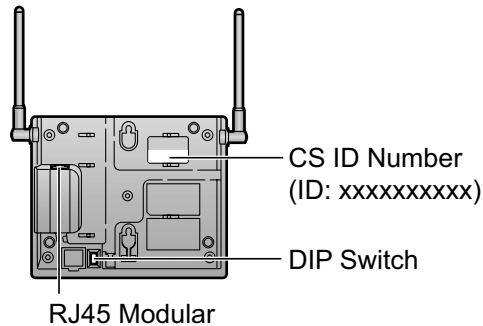
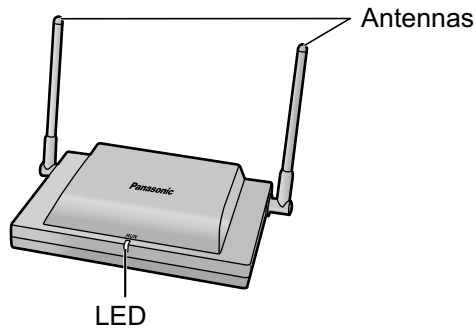

## LED Indications

Indication	Color	Description
STATUS	Green/Red	<p>CS status indication</p> <ul style="list-style-type: none"> <li>• OFF: Power Off</li> <li>• Green ON: Stand-by (no active calls)</li> <li>• Slow Green Flashing (60 times per minute): Talk (active calls)</li> <li>• Moderate Green Flashing (120 times per minute): Busy</li> <li>• Red ON: Fault (includes Initialization)</li> <li>• Red Flashing (60 times per minute): Out of Service/Starting up</li> </ul> <p>CS status indication during the site survey</p> <ul style="list-style-type: none"> <li>• Red ON: The CS is connected to an AC adaptor/battery box.</li> <li>• Red Flashing (60 times per minute): The CS is connected to the PBX.</li> </ul>

## Compatible PBX

Cell Station	PBX	
	Model No.	MPR Software Version
KX-T0155	KX-TAW848	PSMPR Software File Version 3.0000 or later
	KX-TDA50	
	KX-TDA100	PMPR Software File Version 3.0000 or later
	KX-TDA200	
	KX-TDA600	PLMPR Software File Version 3.1000 or later
	KX-TDE100	PMPMPR Software File Version 1.0000 or later
	KX-TDE200	
	KX-TDE600	PGMPR Software File Version 2.0000 or later
	KX-NCP500	PBMPR Software File Version 1.0000 or later
	KX-NCP1000	
KX-T0158	KX-TDA50	PSMPR Software File Version 5.0000 or later
	KX-TDA600	PLMPR Software File Version 5.0000 or later
	KX-TDE100	PMPMPR Software File Version 1.0000 or later
	KX-TDE200	
	KX-TDE600	PGMPR Software File Version 2.0000 or later
	KX-NCP500	PBMPR Software File Version 1.0000 or later
	KX-NCP1000	
KX-TDA0156	KX-TDA100	PMPR Software File Version 3.0000 or later
	KX-TDA200	
	KX-TDA600	PLMPR Software File Version 3.1000 or later
	KX-TDE100	PMPMPR Software File Version 1.0000 or later
	KX-TDE200	
	KX-TDE600	PGMPR Software File Version 2.0000 or later

## Maximum Number of Calls

Cell Stations (CSs) determine the area covered by the wireless system. The number of calls that can be made simultaneously through each CS varies depending on the model, as follows:

Cell Station	Maximum Calls	Compatible Portable Station
KX-T0155	2	<ul style="list-style-type: none"> <li>• KX-TD7685</li> <li>• KX-TD7695</li> <li>• KX-TD7696</li> </ul>
KX-T0158	8	
KX-TDA0156	4	



**Note**

For more details about the Portable Station (PS), refer to the Operating Instructions of the PS.

**Maximum Number of CSs Supported by PBX****Notice**

The CSs are for connection to specified Panasonic PBXs only.

The following number of CSs can be supported by each PBX.

PBX	Connected via	Maximum Number		
		KX-T0155	KX-T0158	KX-TDA0156
KX-TAW848	<ul style="list-style-type: none"> <li>Hybrid Ports</li> <li>HLC card</li> </ul>	4	-	-
KX-TDA50 (with Additional AC Adaptor)	<ul style="list-style-type: none"> <li>Super Hybrid Ports</li> <li>HLC card</li> <li>DLC card</li> </ul>	8	4	-
KX-TDA100/KX-TDA200	<ul style="list-style-type: none"> <li>DHLC card</li> <li>DLC card</li> </ul>	32	-	-
	<ul style="list-style-type: none"> <li>CSIF card</li> </ul>	-	-	32
KX-TDA600	<ul style="list-style-type: none"> <li>DHLC card</li> <li>DLC card</li> </ul>	128	64	-
	<ul style="list-style-type: none"> <li>CSIF card</li> </ul>	-	-	128
KX-TDE100/KX-TDE200	<ul style="list-style-type: none"> <li>DHLC card</li> <li>DLC card</li> </ul>	32	16	-
	<ul style="list-style-type: none"> <li>CSIF card</li> </ul>	-	-	32
KX-TDE600	<ul style="list-style-type: none"> <li>DHLC card</li> <li>DLC card</li> </ul>	128	64	-
	<ul style="list-style-type: none"> <li>CSIF card</li> </ul>	-	-	128
KX-NCP500	<ul style="list-style-type: none"> <li>DHLC card</li> <li>DLC card</li> </ul>	4	2	-
KX-NCP1000	<ul style="list-style-type: none"> <li>DHLC card</li> <li>DLC card</li> </ul>	8	4	-

**Required Distances between Equipment****CAUTION**

Maintain the distances listed below between equipment in order to prevent noise, interference or the disconnection of a conversation. (The distance may vary depending on the environment.)

Equipment	Distance
CS and office equipment such as a computer, telex, fax machine, etc.	More than 2 m (6 ft 7 in)

Equipment	Distance
CS and PS	More than 1 m (3 ft 3 in)
Each CS	More than 3 m (10 ft)
Each PS	More than 0.5 m (1 ft 8 in)
PBX and CS	More than 2 m (6 ft 7 in)

If multiple CSs cover the same area, the phone connection may become noisy or the number of possible simultaneous calls with PSs may decrease due to interference between the CSs. For details, refer to "5 Site Survey—Testing the Radio Signal Strength".

The required distance between CSs may vary depending on the environment of the installation site and conditions in which the wireless system is used. Conduct a site survey to determine the appropriate distance.

## RF Specification

Item	Description
Radio Access Method	MultiCarrier TDMA-TDD
Frequency Band	1920 MHz to 1930 MHz
Number of Carriers	5
Carrier Spacing	1728 kHz
Bit Rate	1152 kbps
Carrier Multiplex	TDMA, 24 (Tx12, Rx12) slots per frame
Frame Length	10 ms
Modulation Scheme	GFSK
	Roll-off factor=0.5 50 % roll-off in the transmitter
Data Coding for Modulator	Differential Coding
Voice CODEC	32 kbps ADPCM (CCITT G.726)

### CAUTION

- The CS should be kept free of dust, moisture, high temperature (more than 40 °C [104 °F]), low temperature (less than 0 °C [32 °F]), and vibration, and should not be exposed to direct sunlight.
- The CS should not be placed outdoors (use indoors).
- The CS should not be placed near high-voltage equipment.
- The CS should not be placed on a metal object.

## 2 Procedure Overview

When connecting the wireless system, use extreme care in conducting the site survey. An incorrectly performed site survey can result in poor service area, frequent noise, and disconnection of calls.

### Notice

- When installing the DECT 6.0 wireless system in an area where another wireless system (2.4 GHz) is already installed, it is necessary to reconduct the site survey to find the optimum position for the CS. If you install the new CS in the same position as the old CS, it may result in a poor service area, frequent noise, and disconnection of calls.
- In this case, it is necessary to perform system initialization. For details about the system initialization procedure, refer to "Starting the PBX" in the Installation Manual for your PBX.

### 1. Investigate the installation site

Refer to "3 Site Planning".

- Obtain a map of the CS installation site.
- Identify the service area required by the user on the map.
- Plan the location of each CS, taking account of distance, building materials, etc.

### 2. Prepare for site survey

Refer to "4 Before Site Survey".

- Check and assign the CS ID number to the PS.
- Assign a channel number to each CS by setting the DIP switches on the back of the CS.
- Supply electricity to each CS using an AC adaptor/battery box or by connecting them to the PBX.
- Install each CS temporarily as planned.

### Note

- Install at least 2 m (6 ft 7 in) above the floor.
- Place the antennas so that they are pointing in directions that are 90 degrees apart (for antenna diversity).

### 3. Conduct the site survey

Refer to "5 Site Survey".

- Test the radio signal strength using the PS.  
Confirm that the radio signal strength level is "12" near the CS.

#### Using the KX-TD7685/KX-TD7695/KX-TD7696

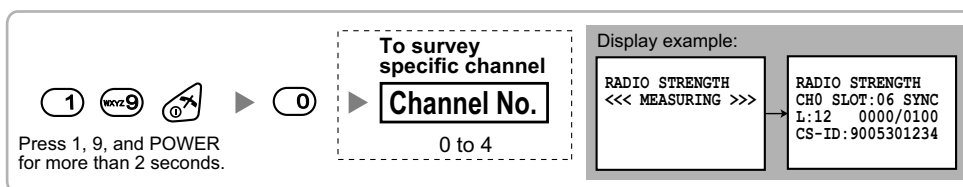

- By walking away from the CS with the PS, check the radio signal strength. The radio signal strength weakens as you walk away from the CS.
- Map the CS coverage area at radio signal strength levels "3" and "8".
- Make sure that adjacent CS coverage areas meet where the radio signal strength level is "7" to "9".

- e. Make sure that the radio signal strength level is greater than "3" at any location within the service area required by the user.

#### 4. Finish the site survey

Refer to "6 After Site Survey".

- a. Turn off the PS.
- b. Stop supplying power, and return all DIP switches of each CS to the OFF position.

#### 5. Connect the CS and PS to the PBX and test the operation

Refer to "7 Connecting a Cell Station to the PBX".

- a. Connect the CSs to the PBX.
- b. Register the PSs to the PBX.
- c. Walk around the service area while having a conversation using a registered PS. If noise is frequent or conversations disconnect, relocate the CSs or install an additional CS.

#### 6. Mount the CS on the wall

Refer to "8 Wall Mounting".

- a. If there are no problems in testing, mount the CS on the wall.

## 3 Site Planning

Choosing the best site for the CS requires careful planning and testing of essential areas. The best location may not always be convenient for installation. Read the following information before installing the unit.

### Understanding Radio Waves

#### Characteristics of Radio Waves

The transmission of radio waves and the CS coverage area depend on the structure and materials of the building.

Office equipment, such as computers and fax machines, can interfere with radio waves. Such equipment may create noise or interfere with the performance of the PS.

The illustration below shows the special transmitting patterns of radio waves.

1. Radio waves are reflected by objects made of materials such as metal.
2. Radio waves are diffracted by objects such as metallic columns.
3. Radio waves penetrate objects made of materials such as glass.

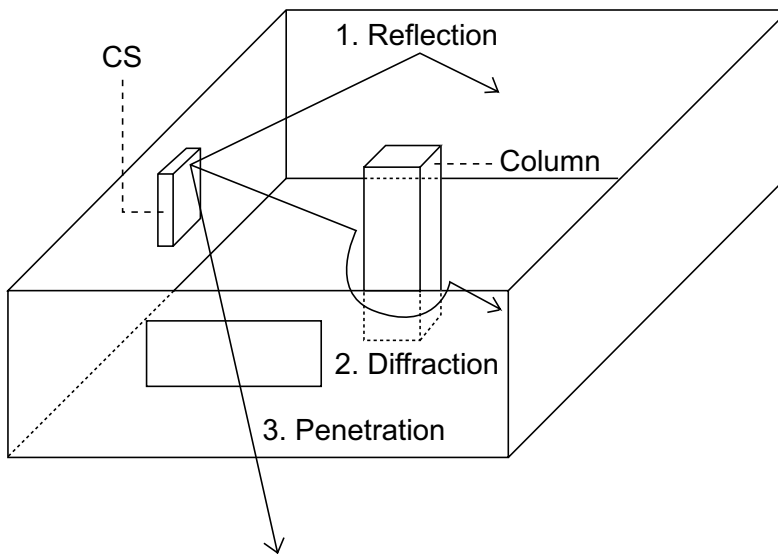

#### Relationships between Radio Waves and Building Structure and Materials

- The CS coverage area is affected more by the building materials and their thickness than the number of obstacles.
- Radio waves tend to be reflected or diffracted by conductive objects and rarely penetrate them.
- Radio waves tend to penetrate insulated objects and are rarely reflected by them.
- Radio waves penetrate thin objects more than thick objects.
- The table below shows the transmission tendency of radio waves when they reach objects made from various materials.

<b>Object</b>	<b>Material</b>	<b>Transmission Tendency</b>
Wall	Concrete	The thicker they are, the less radio waves penetrate them.
	Ferroconcrete	Radio waves can penetrate them, but the more iron there is, the more radio waves are reflected.
Window	Glass	Radio waves usually penetrate them.
	Glass with wire net	Radio waves can penetrate them, but tend to be reflected.
	Glass covered with heat-resistant film	Radio waves are weakened considerably when they penetrate windows.
Floor	Ferroconcrete	Radio waves can penetrate them, but the more iron there is, the more radio waves are reflected.
Partition	Steel	Radio waves are reflected and rarely penetrate them.
	Plywood, Glass	Radio waves usually penetrate them.
Column	Ferroconcrete	Radio waves can penetrate them, but the more iron there is, the more radio waves tend to be reflected or diffracted.
	Metal	Radio waves tend to be reflected or diffracted.
Cabinet	Steel	Radio waves are usually reflected or diffracted, and rarely penetrate them.
	Wood	Radio waves can penetrate them, but they are weakened.

## CS Coverage Area

The example below shows the size of the coverage area of 1 CS if it is installed in an area with no obstacles.

### Note

Radio signal strength levels are measured during the site survey (refer to "5 Site Survey").

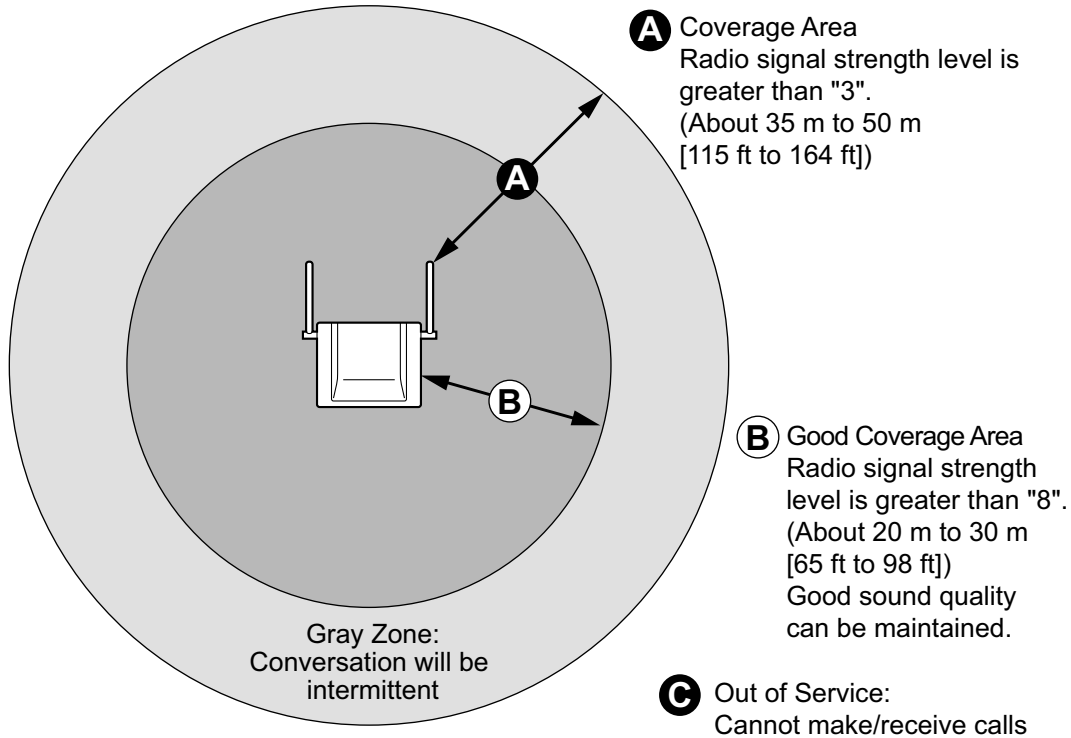

### Radio Signal Strength Levels

Level: 11 to 12		Better
Level: 08 to 10		Good
Level: 03 to 07		May receive noise
Level: 01 to 02		Receives noise easily or disconnects
Level: 00		Out of range

## Site Survey Preparation

1. Obtain a map and investigate the installation site.
  - a. Check the obstacles (e.g., shelves, columns, and partitions).
  - b. Check the materials of the structures (e.g., metal, concrete, and plywood).
  - c. Check the layout and dimensions of the room, corridor, etc.
  - d. Write down the above information on the map.
2. Examine the service area required by the user on the map, referring to the following example.
  - a. Draw the coverage area around a CS. Extend the coverage area 20 m to 50 m (65 ft to 164 ft) in each direction, depending on the materials of the building structures and obstacles in the installation site. Note that a CS cannot be installed outside a building.

- b. If 1 CS cannot cover the entire service area, install additional CSs as required. Overlap the coverage areas of adjacent CSs.

Where CS coverage areas overlap, the PS will start call handover to the next CS if the signal from one CS becomes weak. However, if a PS moves away from a CS and there are no CSs available for handover, the PS may go out of range and the call could be lost.

### Example: Installing in a Room Separated by Interior Walls

#### Things to take note of:

- The room is separated by interior walls.
- The room is surrounded by concrete walls.

#### CS installation plan:

- The coverage area of each CS will not extend as far as when there are no obstacles, because the radio signals will be weakened by separating walls. Therefore, you will need 5 CSs to cover the entire room.

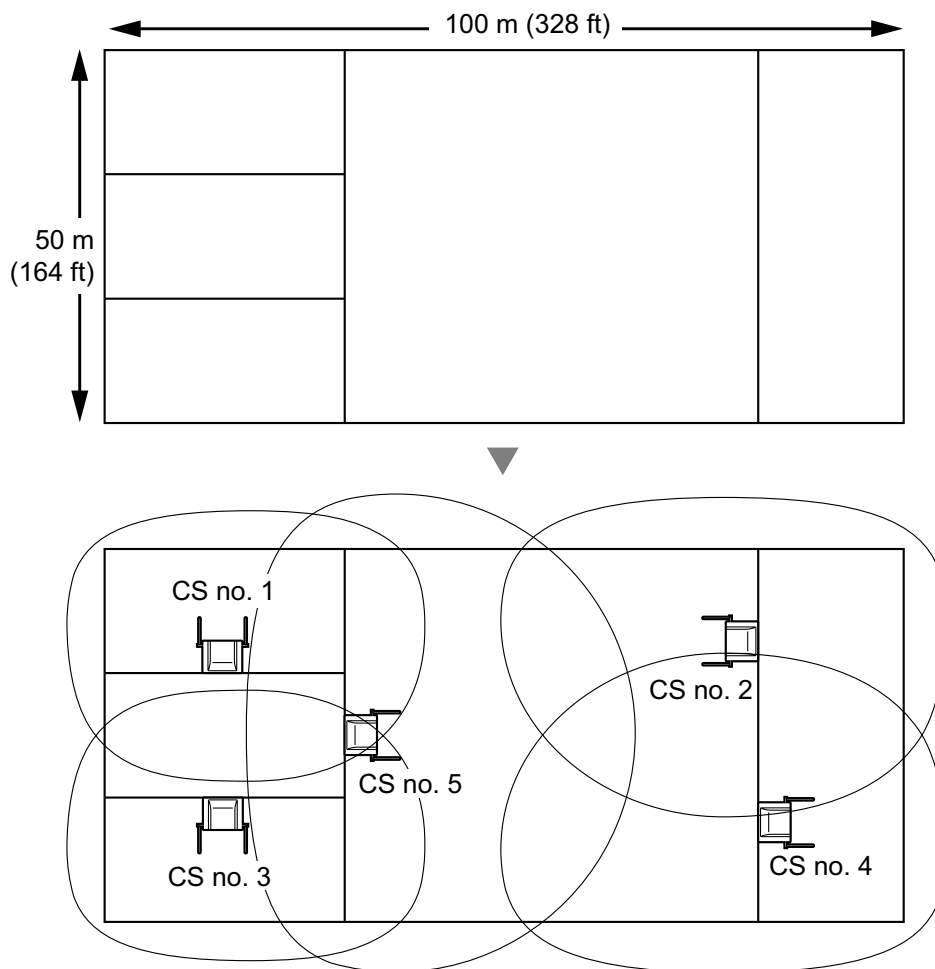



# 4 Before Site Survey

Use the KX-TD7685/KX-TD7695/KX-TD7696 PS to conduct the site survey.

**Note**

Display prompts for the site survey are only available in English.

## Checking the CS ID Number

Check the CS ID number label attached to the CS. If the CS ID number label is not attached to the CS, check the CS ID number using the Maintenance Console. For details, refer to "Utility—CS Information" in the PC Programming Manual for your PBX.

## Assigning the CS ID Number to the PS

Using the KX-TD7685/KX-TD7695/KX-TD7696

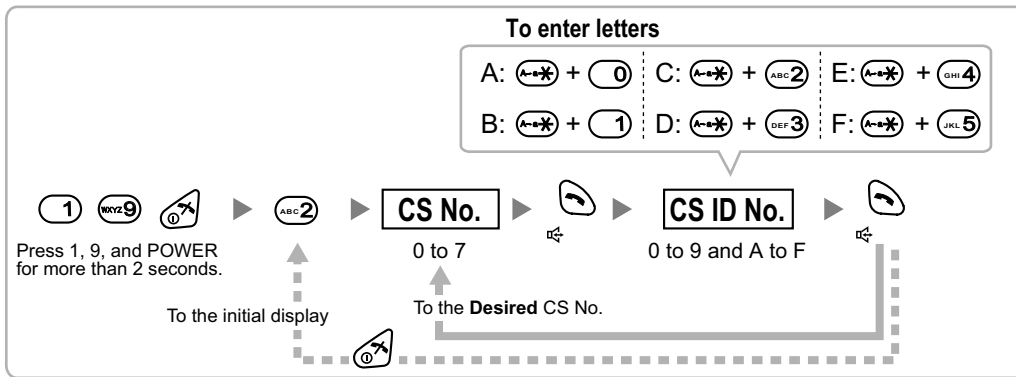

**Note**

To clear the CS ID number assigned to the PS, follow the procedure below:

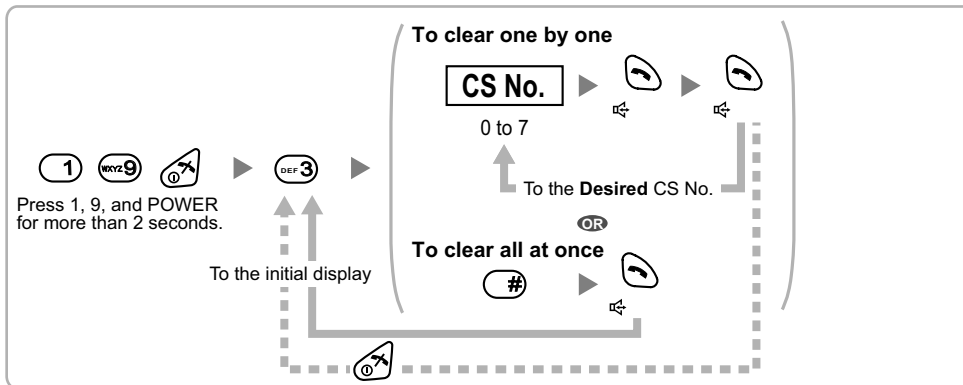

## Setting and Installing the CS Temporarily for Site Survey

1. Switch the Radio Signal Test switch from OFF to ON.
2. Set the channel number switches as desired.
3. Set the Power Supply Select switch as desired.

### KX-T0155/KX-TDA0156

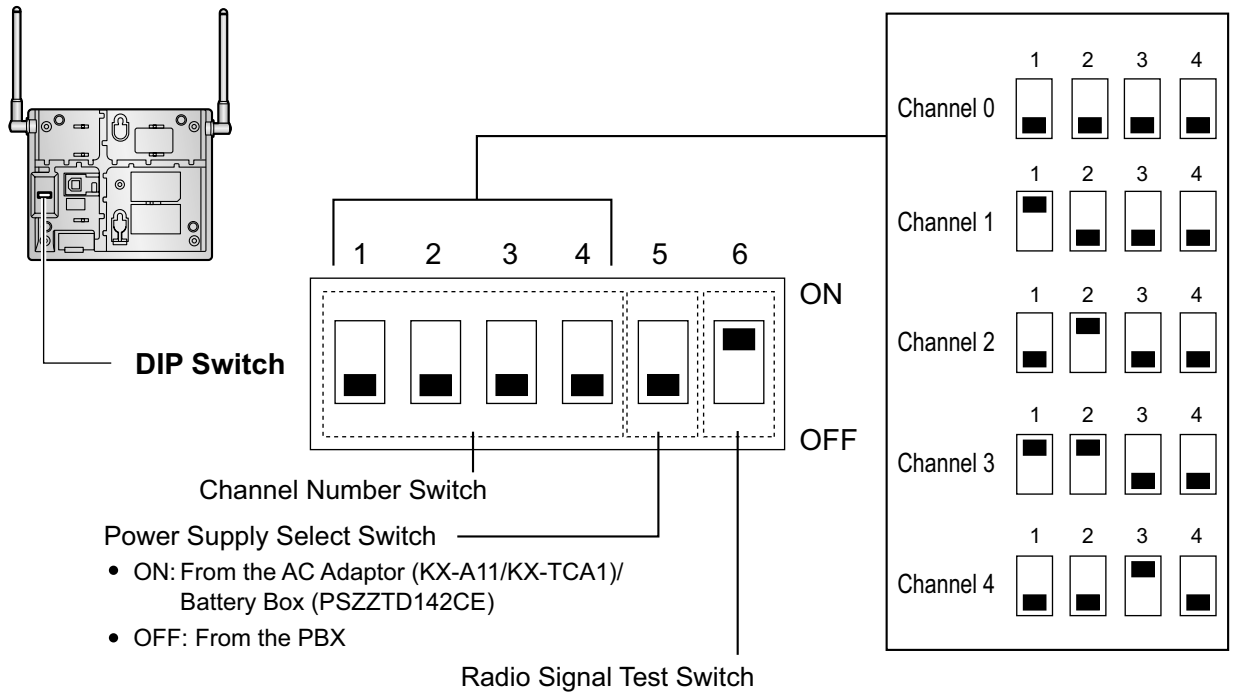

**KX-T0158**

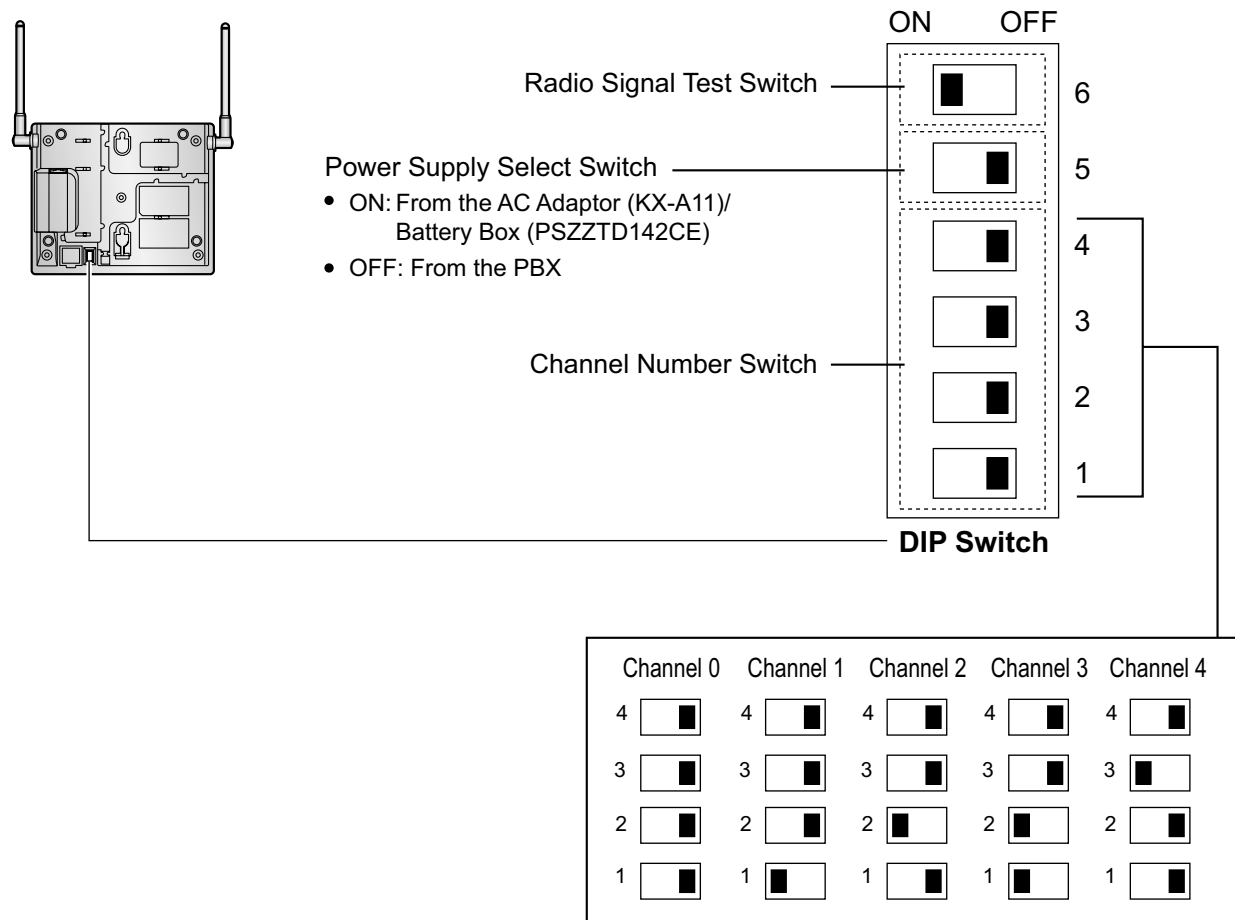

**Note**

If more than 1 CS is in Radio Signal Test mode, each CS must have a unique channel number.

4. After setting the DIP switches, connect the CS to an AC adaptor/battery box using a power supply adaptor, or connect it to the PBX.

**WARNING**

**When installing or testing a product with an external AC adaptor, the AC adaptor should be plugged into a wall outlet or floor-mounted AC outlet. Do not connect the AC adaptor to a ceiling-mounted AC outlet, as the weight of the adaptor may cause it to become disconnected.**

**Notice**

- When using the KX-T0158, it is NOT recommended to conduct the site survey using the battery box.
- If the Power Supply Select switch is set to ON in step 3, connect the CS to an AC adaptor/battery box. If it is set to OFF, connect the CS to the PBX.

**KX-T0155/KX-TDA0156**

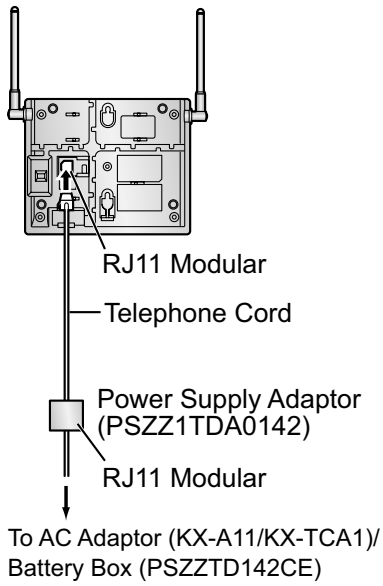

**OR**

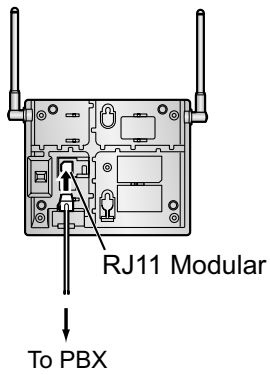

**KX-T0158**

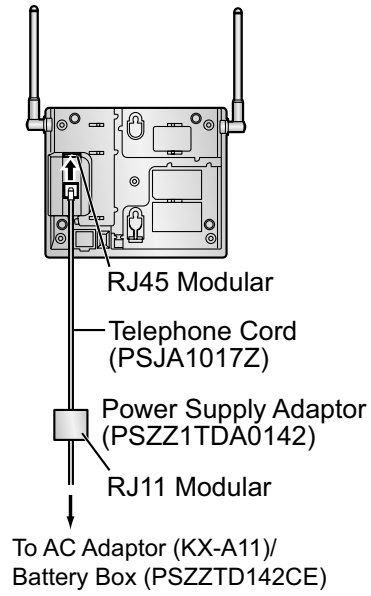

**OR**

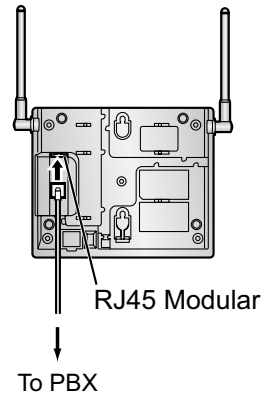

## 4 Before Site Survey

---

5. Install the CS temporarily for the site survey. Install the CS at least 2 m (6 ft 7 in) above the floor, and place the antennas so that they are pointing in directions that are 90 degrees apart (for antenna diversity), as follows:

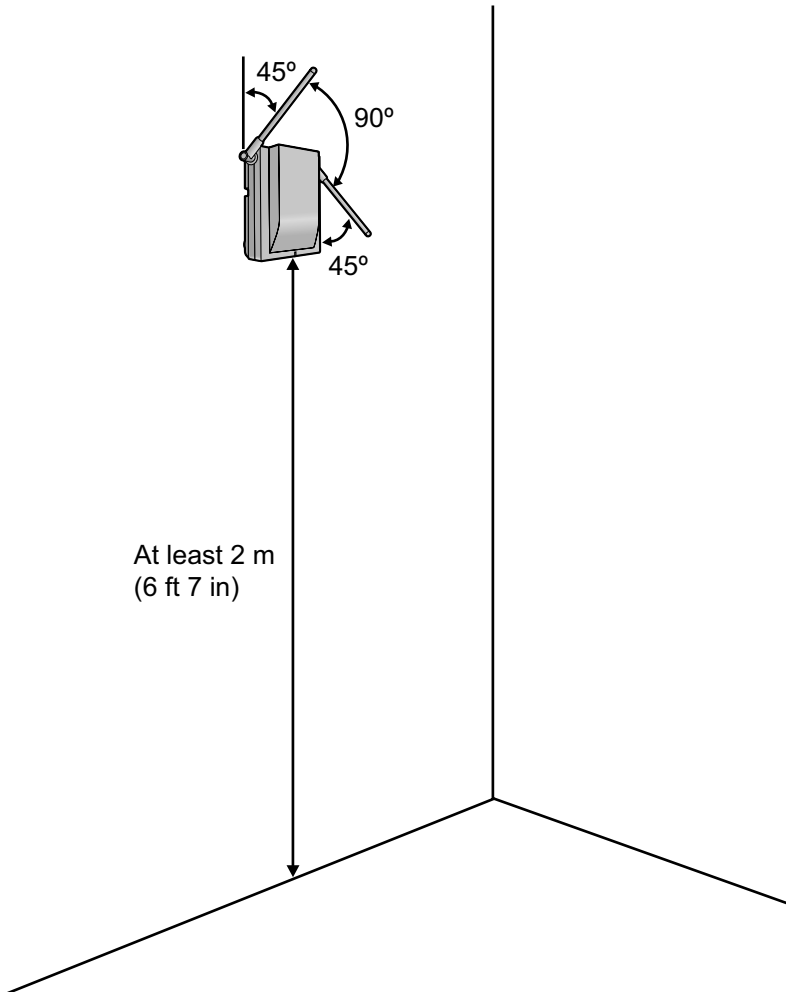

## 5 Site Survey

The PS has a Radio Signal Test mode that monitors the state of the radio link to the CS for site survey. In Radio Signal Test mode, the frame loss and signal strength of a synchronous slot, and the signal strength of the other slots can be measured when the PS is monitoring the CS. After installing the CSs temporarily as planned during site planning, set the PS to Radio Signal Test mode and locate each CS to measure its coverage area. Then, record the results on the map of the installation site.

### Testing the Radio Signal Strength

After locating the CS(s) temporarily, execute the Radio Signal Test using the PS. Directly after entering Radio Signal Test mode, the PS scans channel 0 for a CS that it can connect to. The channel to be scanned can be changed by pressing the appropriate keys 0 through 4.

1. Enter Radio Signal Test mode.

#### Using the KX-TD7685/KX-TD7695/KX-TD7696

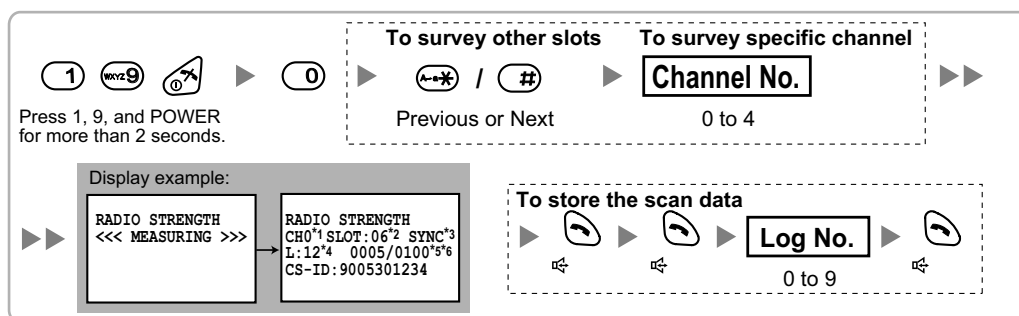

- \*1 Channel number
- \*2 Slot number
- \*3 When a slot is synchronized, "SYNC" is displayed.
- \*4 Radio signal strength level (12 to 00)
- \*5 Frame error (0000 to 9999)/Frame counter (0000 to 9999). Frame error indicates the number of errors out of 10 000 radio signal receptions. An increased number of frame errors indicates greater radio signal interference and more frequent noise during conversation. The ideal number of frame errors is "0000".
- \*6 Error rate (%) = Frame error (0000 to 9999) / Frame counter (0000 to 9999) × 100

#### Note

- Storing the scan data will clear all phonebook data.
  - The PS will not operate in normal mode if scan data is saved on it. For details on clearing scan data, refer to "Clearing the Stored Scan Data".
2. Measure the error rate and the radio signal strength by moving towards and away from the CS.

#### Note

- When the error rate is 2% or more, measure the error rate at the same location at least 5 times. You must disconnect the CS and then reconnect it to take each measurement. If the error rate is consistently 2% or more, there may be interference from external wireless equipment. In this case, the following may happen regardless of the radio signal strength level.

Error Rate	Description
Approx. 2%	May receive noise
Approx. 10%	May fail to make/receive calls

The above is a rough standard, and may vary depending on the environment.

- When deciding where to install the CS, priority should be given to an error rate rather than a radio signal strength level.
- After installing the CS according to the results of the survey, confirm that calls can be made and received, and conversations can be heard clearly.
- a.** Move to the CS until the radio signal strength level becomes "12".
- b.** Move away from the CS and identify the CS coverage area within which the radio signal strength level is greater than "8". Draw the area on the map.
- c.** Move away from the CS and identify the CS coverage area within which the radio signal strength level is greater than "3". Draw the area on the map.

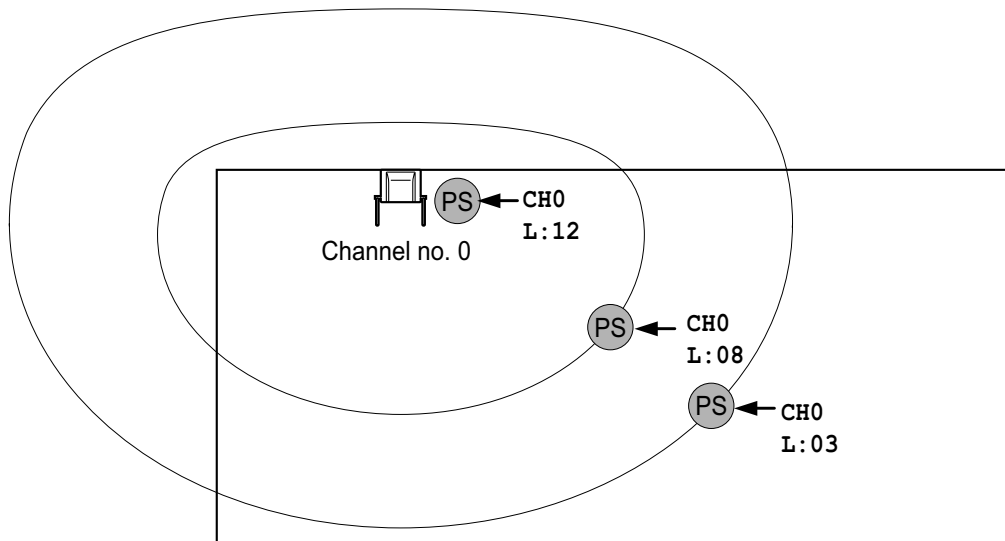

**Radio Signal Strength Levels**

Level: 11 to 12		Better
Level: 08 to 10		Good
Level: 03 to 07		May receive noise
Level: 01 to 02		Receives noise easily or disconnects
Level: 00		Out of range

3. Repeat steps 1 and 2 for other CSs, and relocate the CSs when necessary.
  - a. Plan adjacent CS coverage areas so that areas meet where radio signal strength level is "7" to "9".

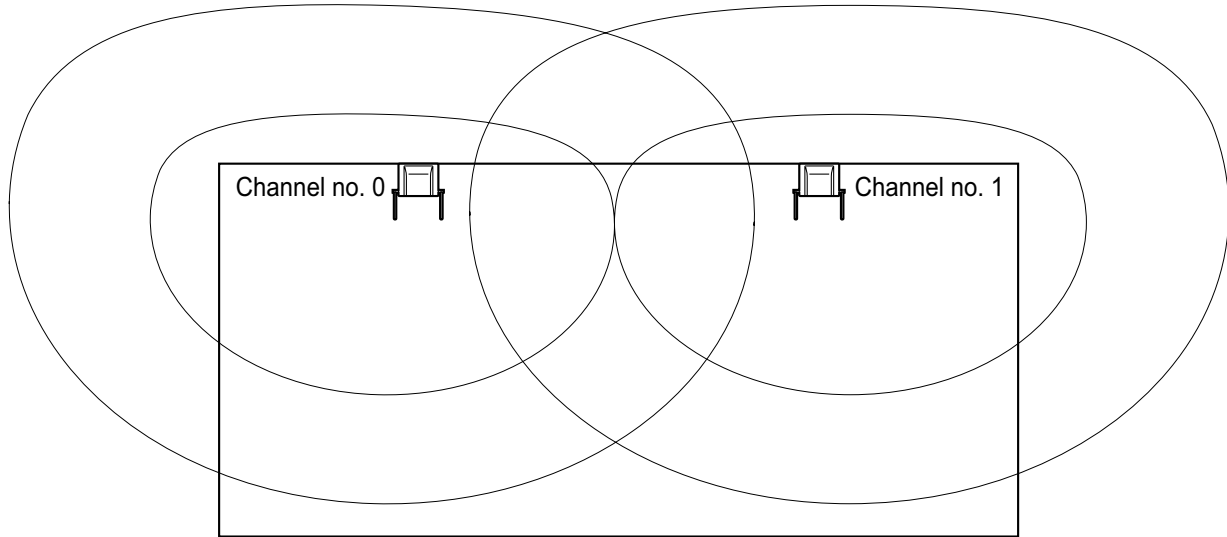

- b. Plan the CS coverage areas to meet for at least 2 CSs at any location in the installation site.

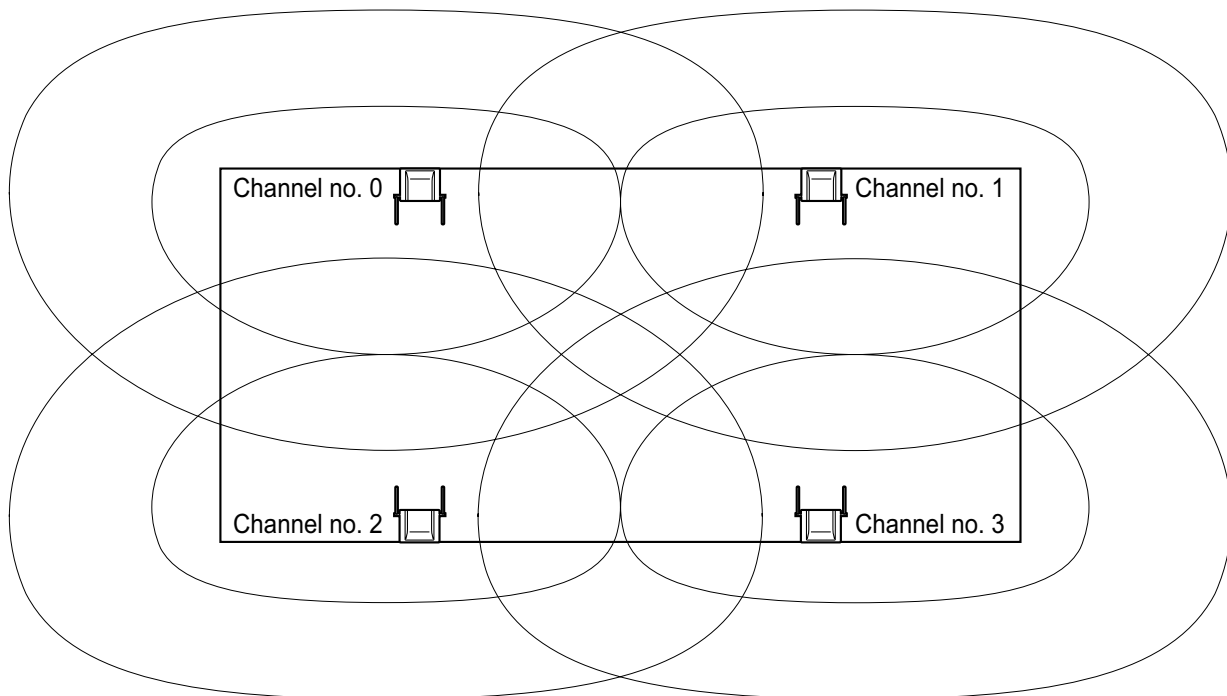

- c. Make sure that the radio signal strength level is greater than "3" at any location in the service area required by the user.

#### **Note**

- If a channel is set, the results of measurement for the 24 slots on the channel are saved each time. If the same channel is set, the new results override the previous ones. Therefore, a measurement of 5 channels × 24 slots in total can be made.
- If correct results cannot be obtained (e.g., there are many frame errors), change the location of the CS and repeat the site survey to select the best location.



- If multiple CSs cover the same area, the phone connection may become noisy or the number of possible simultaneous calls with PSs may decrease due to interference between the CSs. As a guideline, the maximum number of CSs in an area with a radio signal strength of "11" is 4 (for KX-T0155)/2 (for the KX-T0158/KX-TDA0156).

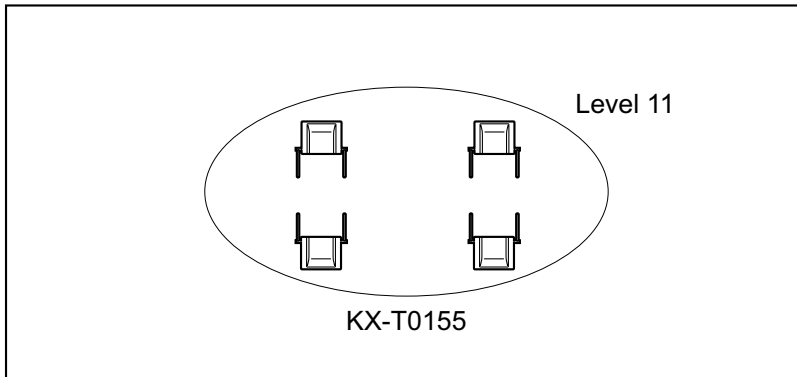

To guarantee the number of simultaneous calls, the KX-T0158 is recommended.

## Referring to the Stored Scan Data

### Using the KX-TD7685/KX-TD7695/KX-TD7696

Press 1, 9, and POWER for more than 2 seconds.
   
 0 to 9

**To go to other slots**      **To go to specific channel**
  
  
 Previous or Next      0 to 4

## Clearing the Stored Scan Data

### Using the KX-TD7685/KX-TD7695/KX-TD7696

Press 1, 9, and POWER for more than 2 seconds.

## 6 After Site Survey

After obtaining the proper measurement results, exit Radio Signal Test mode before connecting the CS to the PBX.

1. Hold down the POWER button on the PS until the PS is turned OFF.
2. Disconnect the CS from the AC adaptor/battery box or the PBX to stop supplying electricity.

**KX-T0155/KX-TDA0156**

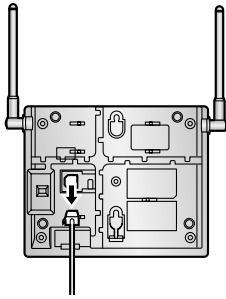

**KX-T0158**

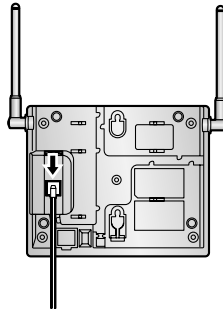

3. Switch all DIP switches on the CS from ON to OFF.

**KX-T0155/KX-TDA0156**

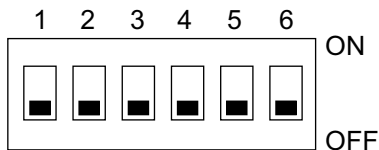

**KX-T0158**

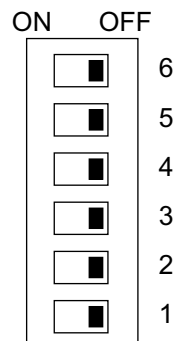

# 7 Connecting a Cell Station to the PBX

## Connection Examples for KX-TAW848/KX-TDA50

Refer to the following examples to connect a CS to the PBX.

### KX-T0155 connecting to KX-TAW848/KX-TDA50

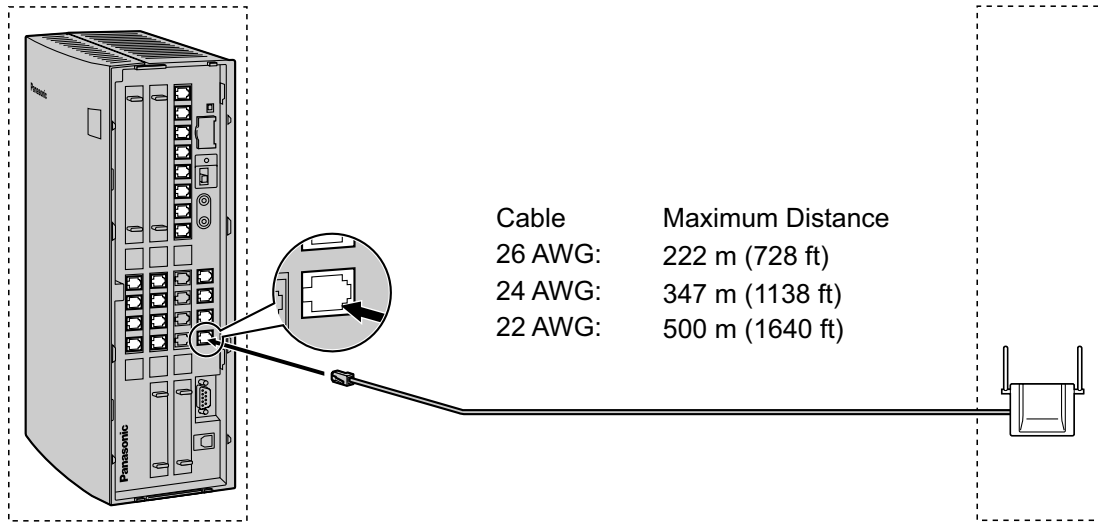

A Super Hybrid Port (Hybrid Port),  
or HLC4/DLC4/DLC8 card (RJ11)

CS (RJ11)

Signal Name	Pin No.	Pin No.	Signal Name
D1	1	1	D1
	2	2	
	3	3	
D2	4	4	D2

### Accessories and User-supplied Items for the CS

**Accessories (included):** Screws × 2, Washers × 2

**User-supplied (not included):** RJ11 connector

### Note

For details about the Super Hybrid Ports (Hybrid Ports) or HLC4/DLC4/DLC8 card, refer to the Installation Manual for your PBX.

**KX-T0158 connecting to KX-TDA50**

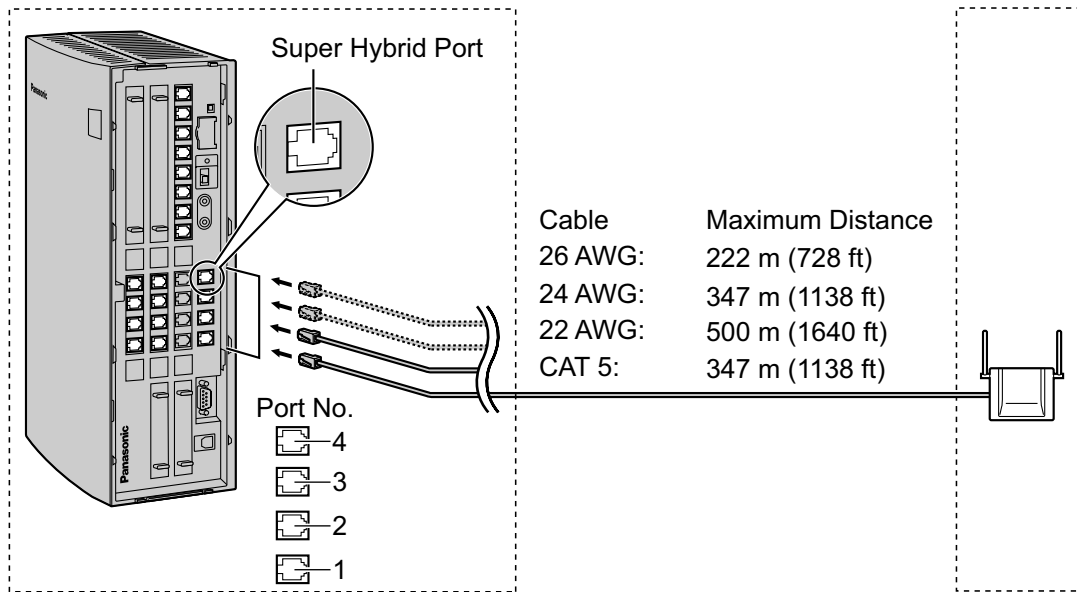

Super Hybrid Ports,  
or HLC4/DLC4 card (RJ11)

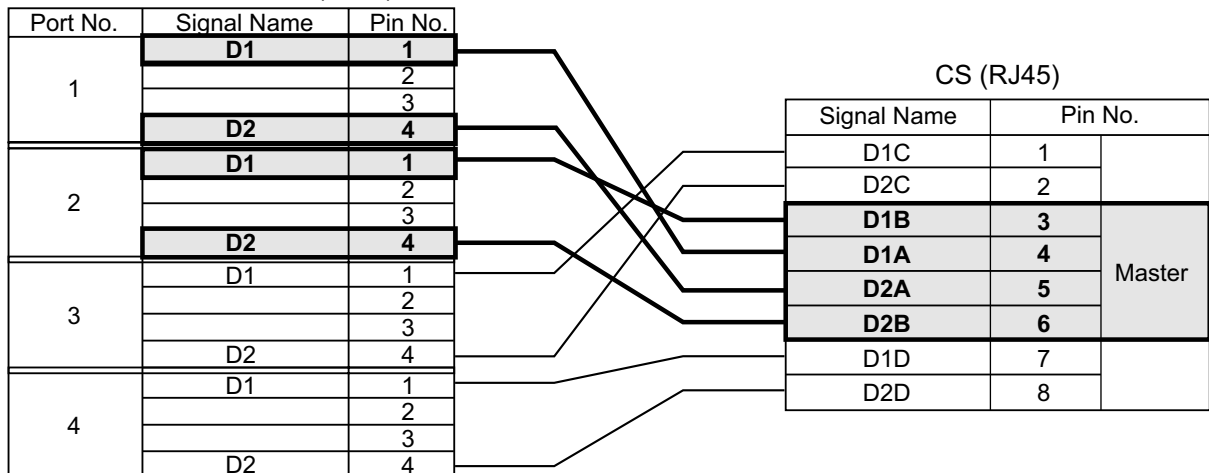

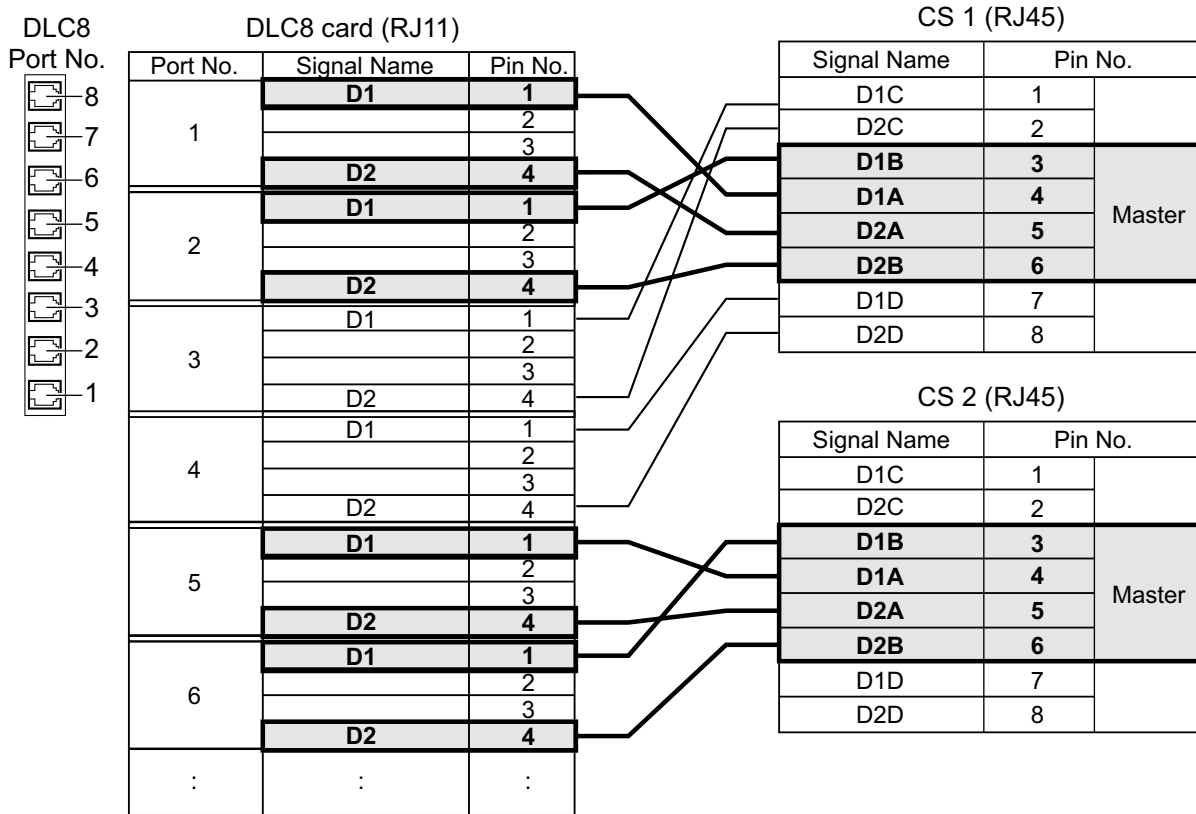

**Accessories and User-supplied Items for the CS**

**Accessories (included):** Screws × 2, Washers × 2

**User-supplied (not included):** RJ45 connector

**Note**

- The no. 3, 4, 5 and 6 pins (Master) of the CS must be connected to 2 pairs of pins on the Super Hybrid Ports or HLC4/DLC4/DLC8 card. Then use 4 consecutive pairs of pins on the Super Hybrid Ports or HLC4/DLC4/DLC8 card, starting with the pins corresponding to the Master, as in the example above.
- When connecting multiple KX-T0158 CSs to a DLC8 card, make sure that the no. 3, 4, 5 and 6 pins (Master) of adjacent CSs are at least 2 pairs of pins away on the card.
- For details about the Super Hybrid Port or HLC4/DLC4/DLC8 card, refer to the Installation Manual for your PBX.
- CS connections must be made within the Super Hybrid Ports or the same HLC4/DLC4/DLC8 card.
- When a wrong connection is made, satisfactory performance of the CS cannot be guaranteed. Check the connection of CS and the PBX using the Maintenance Console. For information about how to view CS information using the Maintenance Console, refer to "Utility—CS Information" in the PC Programming Manual for your PBX.

## Connection Examples for KX-TDA100/KX-TDA200/KX-TDA600/KX-TDE100/ KX-TDE200/KX-TDE600

### Note for KX-TDE100/KX-TDE200 (PMMPR Software File Version 1.xxxx) Users

When connecting both KX-T0155 and KX-T0158 CSs to the same card, the KX-T0158 CSs must be connected to lower-numbered pins on the card than the KX-T0155 CSs.

Refer to the following examples to connect a CS to the PBX.

### KX-T0155 connecting to KX-TDA100/KX-TDA200/KX-TDA600/KX-TDE100/KX-TDE200/ KX-TDE600

#### Note

The illustration of the PBX is based on the KX-TDE200.

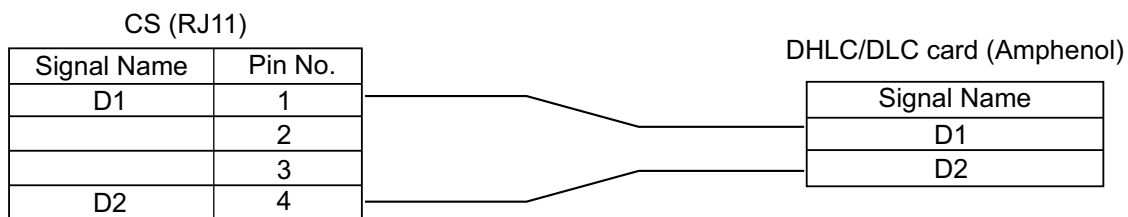
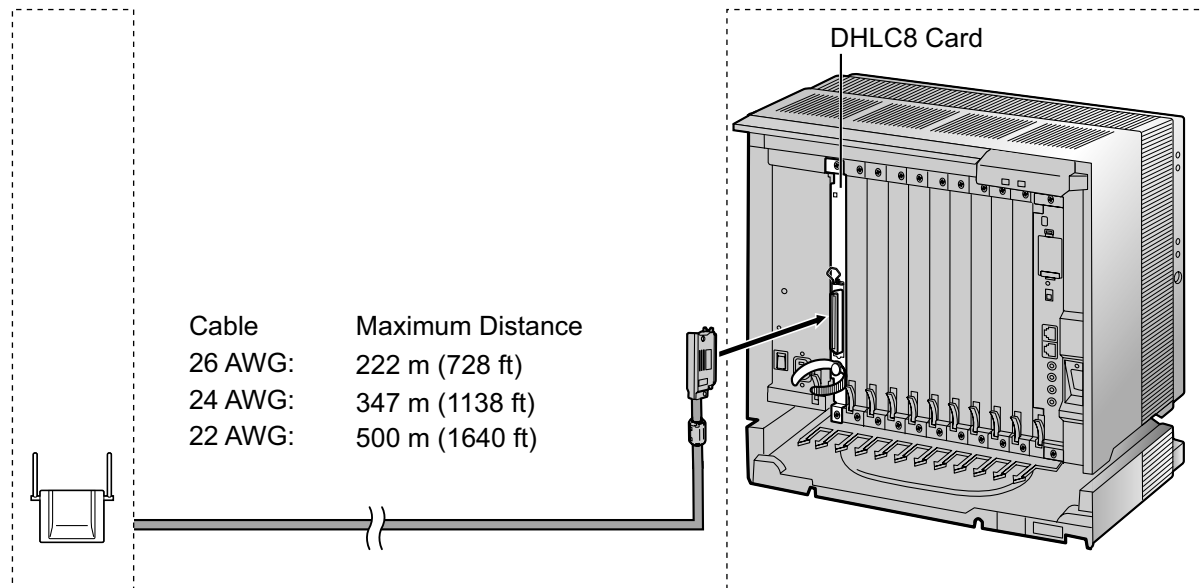

#### Accessories and User-supplied Items for the CS

**Accessories (included):** Screws × 2, Washers × 2

**User-supplied (not included):** RJ11 connector

#### Note

For details about the DHLC/DLC card, refer to the Installation Manual for your PBX.

**KX-T0158 connecting to KX-TDA600/KX-TDE100/KX-TDE200/KX-TDE600**

**Note**

The illustration of the PBX is based on the KX-TDE200.

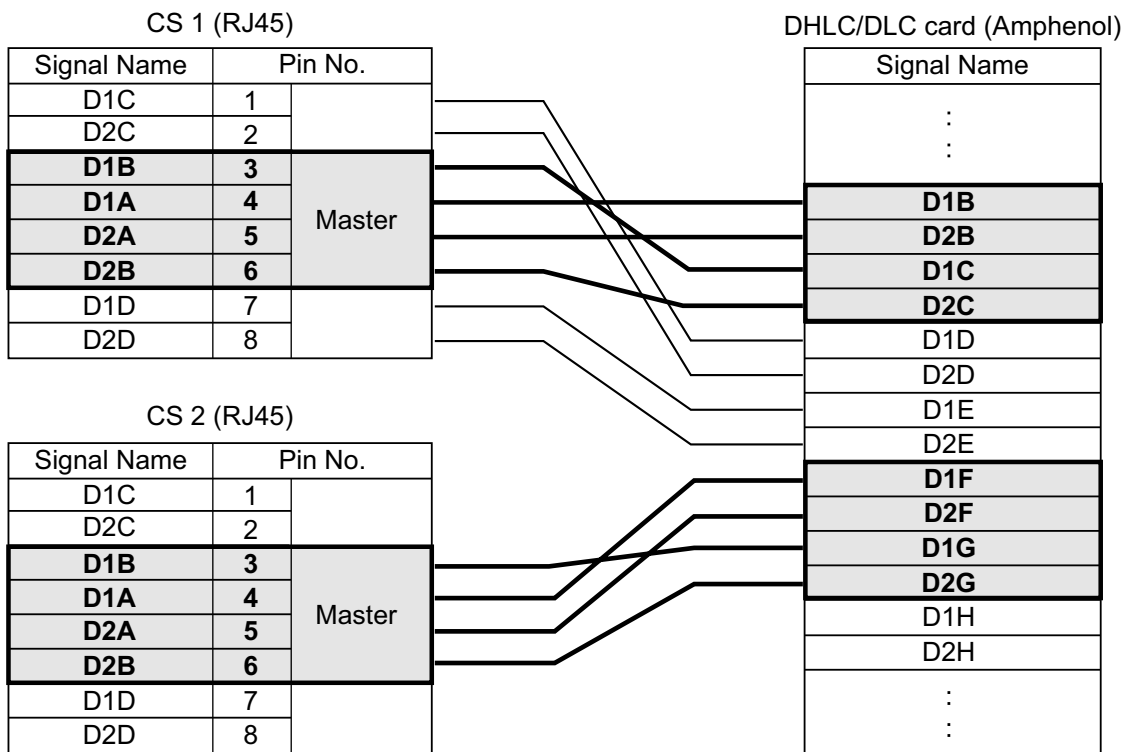
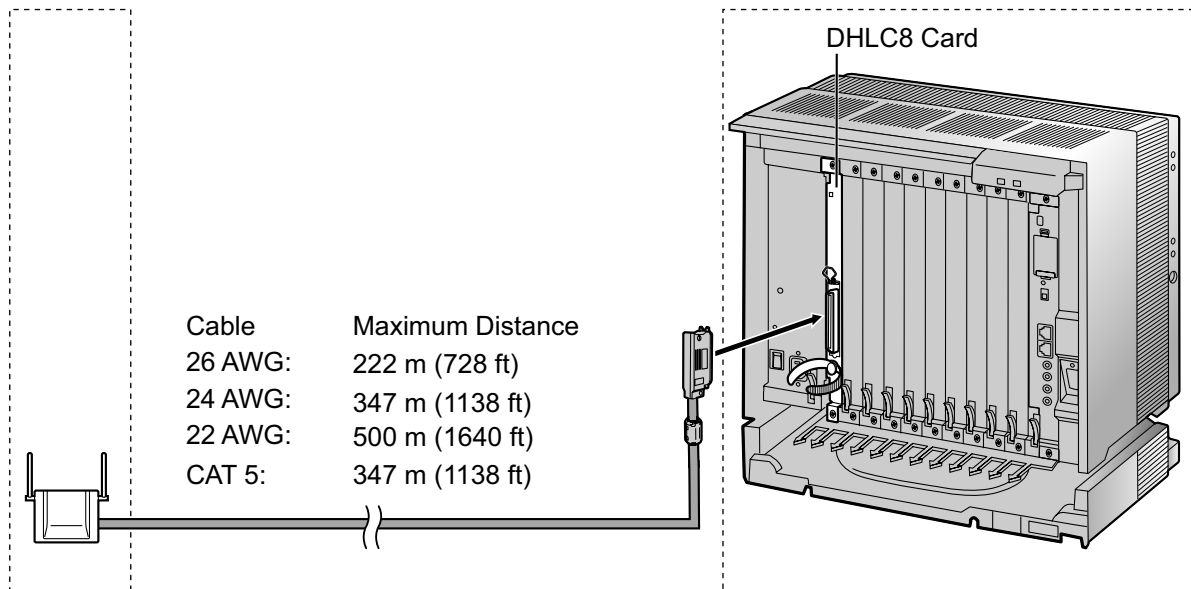

**Accessories and User-supplied Items for the CS**

**Accessories (included):** Screws × 2, Washers × 2

**User-supplied (not included):** RJ45 connector

**Note**

- The no. 3, 4, 5 and 6 pins (Master) of the CS must be connected to 2 pairs of pins on the DHLC/DLC card.
- When connecting multiple KX-T0158 CSs to a DHLC/DLC card, make sure that the no. 3, 4, 5 and 6 pins (Master) of adjacent CSs are at least 2 pairs of pins away on the card.
- For details about the DHLC/DLC card, refer to the Installation Manual for your PBX.
- The Local Processor (LPR) software of the DHLC/DLC card used must be version 5.000 or later. If necessary, upgrade the LPR software of the DHLC/DLC card. To confirm the LPR software version of the card, refer to "Configuration—Slot—Summary" in the PC Programming Manual for your PBX.
- CS connections must be made within the same DHLC/DLC card.
- When a wrong connection is made, satisfactory performance of the CS cannot be guaranteed. Check the connection of CS and the PBX using the Maintenance Console. For information about how to view CS information using the Maintenance Console, refer to "Utility—CS Information" in the PC Programming Manual for your PBX.



**KX-TDA0156 connecting to KX-TDA100/KX-TDA200/KX-TDA600/KX-TDE100/KX-TDE200/  
KX-TDE600**

**Note**

The illustration of the PBX is based on the KX-TDE200.

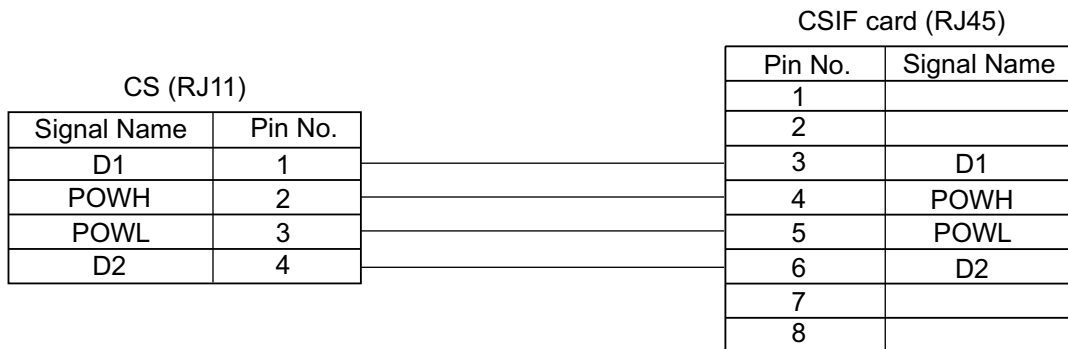
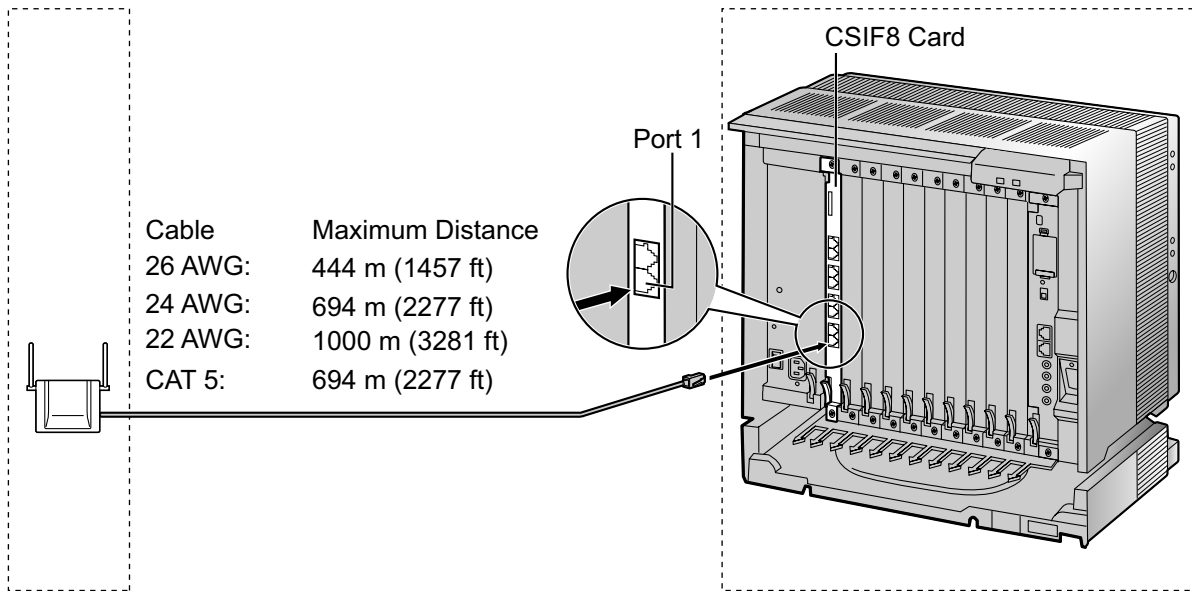

**Accessories and User-supplied Items for the CS**

**Accessories (included):** Screws × 2, Washers × 2

**User-supplied (not included):** RJ11 connector

**Note**

For details about CSIF card, refer to the Installation Manual for your PBX.

## Connection Examples for KX-NCP500/KX-NCP1000

Refer to the following examples to connect a CS to the PBX.

### KX-T0155 connecting to KX-NCP500/KX-NCP1000

#### Note

The illustration of the PBX is based on the KX-NCP500.

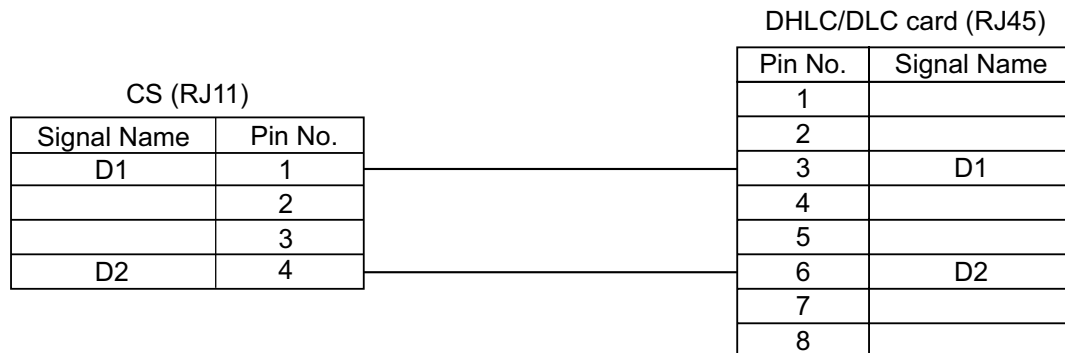
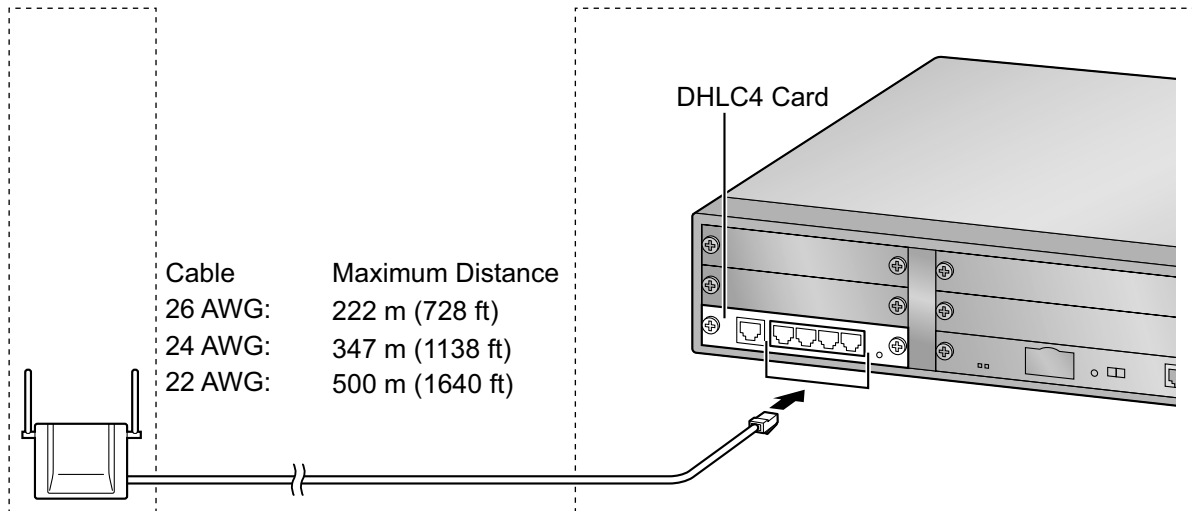

#### Accessories and User-supplied Items for the CS

**Accessories (included):** Screws × 2, Washers × 2

**User-supplied (not included):** RJ11 connector

#### Note

For details about the DHLC/DLC card, refer to the Installation Manual for your PBX.

### KX-T0158 connecting to KX-NCP500/KX-NCP1000

**Note**

The illustration of the PBX is based on the KX-NCP500.

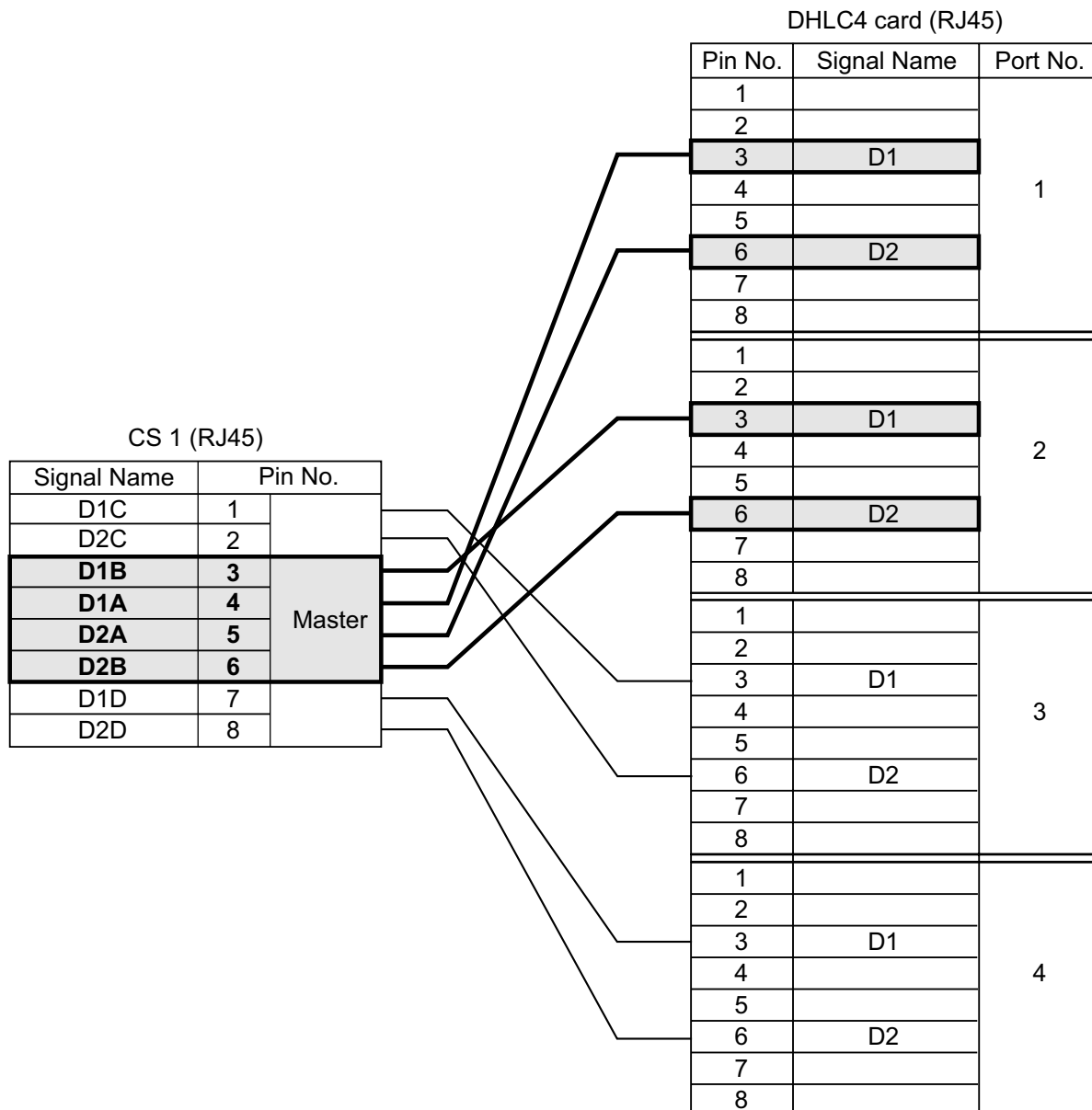
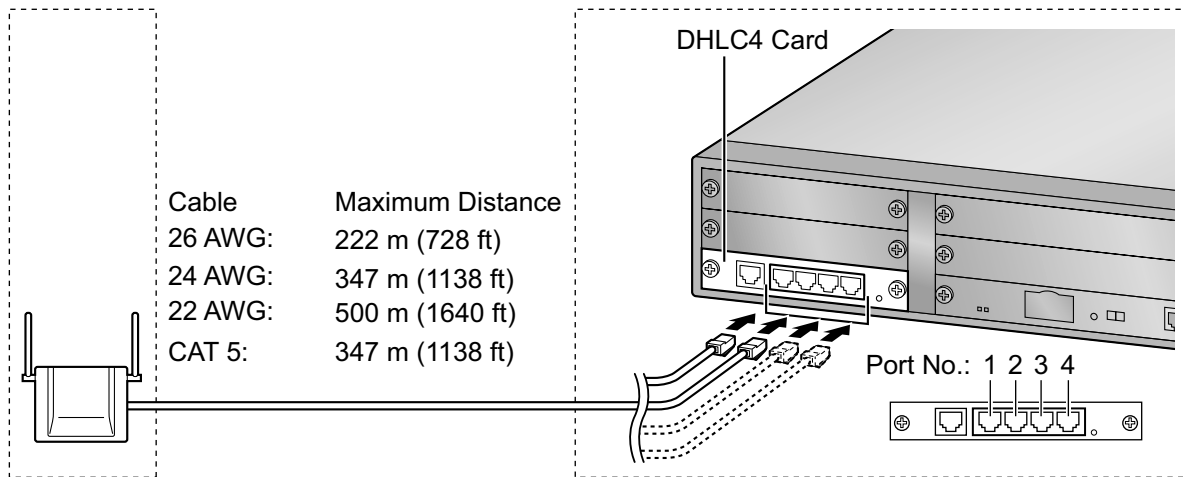

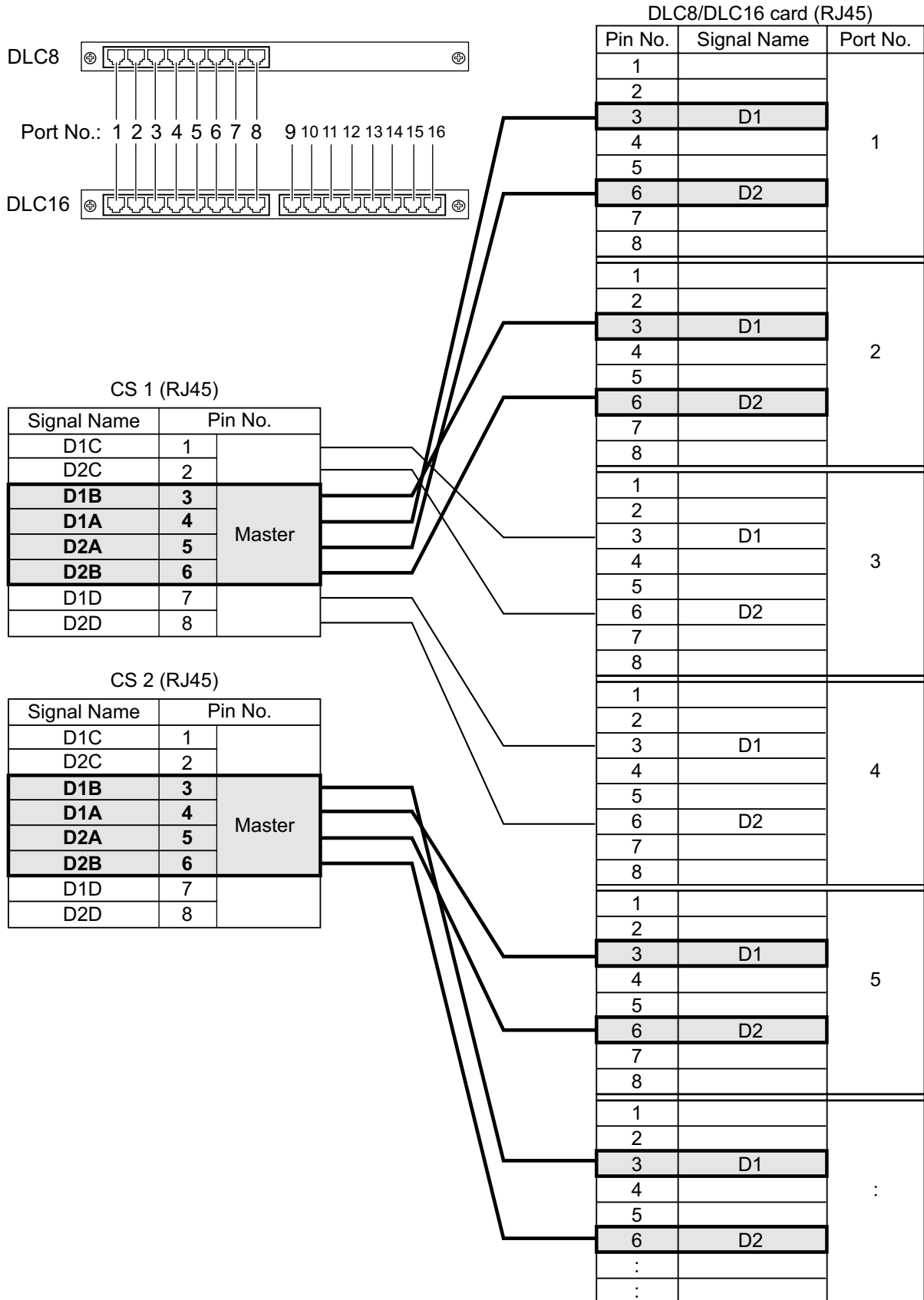

### Accessories and User-supplied Items for the CS

**Accessories (included):** Screws × 2, Washers × 2

**User-supplied (not included):** RJ45 connector

#### **Note**

- The no. 3, 4, 5 and 6 pins (Master) of the CS must be connected to 2 pairs of pins on the DHLC/DLC card.
- When connecting multiple KX-T0158 CSs to a DHLC/DLC card, make sure that the no. 3, 4, 5 and 6 pins (Master) of adjacent CSs are at least 2 pairs of pins away on the card.
- For details about the DHLC/DLC card, refer to the Installation Manual for your PBX.
- CS connections must be made within the same DHLC/DLC card.
- When a wrong connection is made, satisfactory performance of the CS cannot be guaranteed. Check the connection of CS and the PBX using the Maintenance Console. For information about how to view CS information using the Maintenance Console, refer to "Utility—CS Information" in the PC Programming Manual for your PBX.

## Connecting the CS

1. Connect the cable from the PBX to the CS.

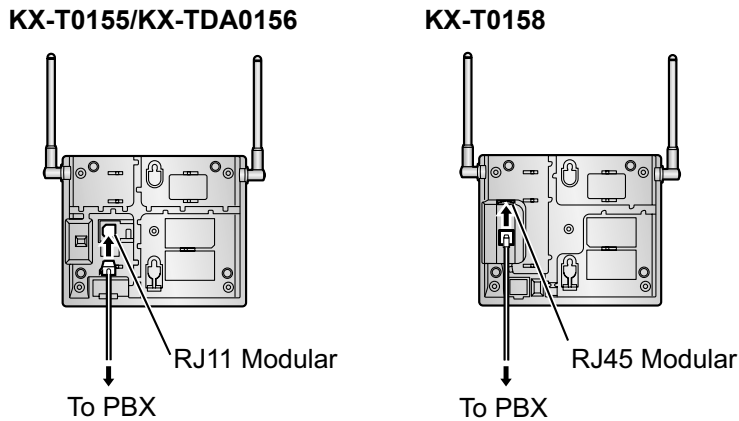

2. Pass the cable through the groove of the CS (in any direction depending on your preference).

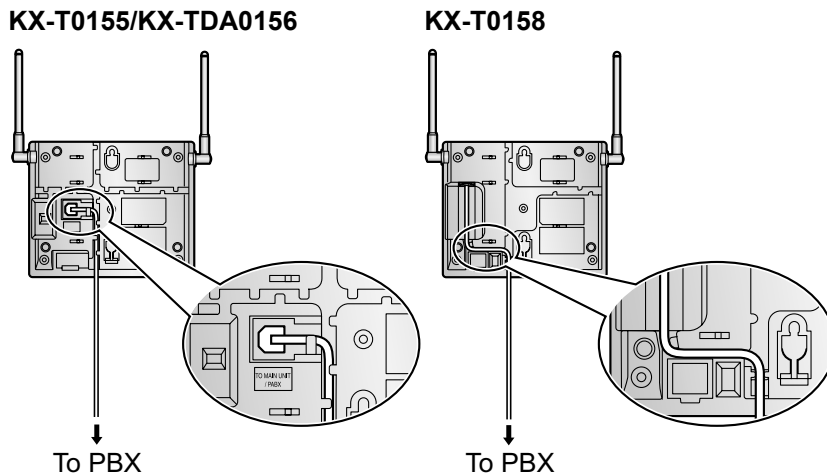

## Registering the PS

The PS must be registered to the PBX before it can be used. Programming of both the PS and PBX is required. A Proprietary Telephone (PT) with multiline display (e.g., KX-T7636 6-line display) is required to perform the PBX system programming.

### Note

For details about system programming using a PT, refer to "PT Programming" in the Feature Manual, and "PT Programming" in the PT Programming Manual for your PBX.

### Entering the System Programming Mode PT (Administrator Level)



**Note**

◆ means default value throughout this section.

**Setting the Personal Identification Number (PIN) for PS Registration**

To prevent registering the PS to a wrong PBX, a PIN for PS registration can be set to the PBX. Before registering the PS to the PBX, enter the PIN set to the PBX into the PS. By doing so, the PS will only be registered to the PBX with the matching PIN.

**CAUTION**

To avoid unauthorized access and possible abuse of the PBX, we strongly recommend:

- a. Keeping the password (PIN for PS registration) secret.
- b. Not using the default password and changing the password regularly.
- c. Selecting a complex, random password that cannot be easily guessed.

**Note**

The PIN for PS registration will only be used when registering the PS to the PBX. Therefore, during normal operation after registration, even if there is more than 1 PBX with the same PIN near the PS, the PS will not be inadvertently linked to a different PBX.

**Setting the PIN for PBX**



**Setting the PIN for PS**

**Using the KX-TD7685/KX-TD7695/KX-TD7696**

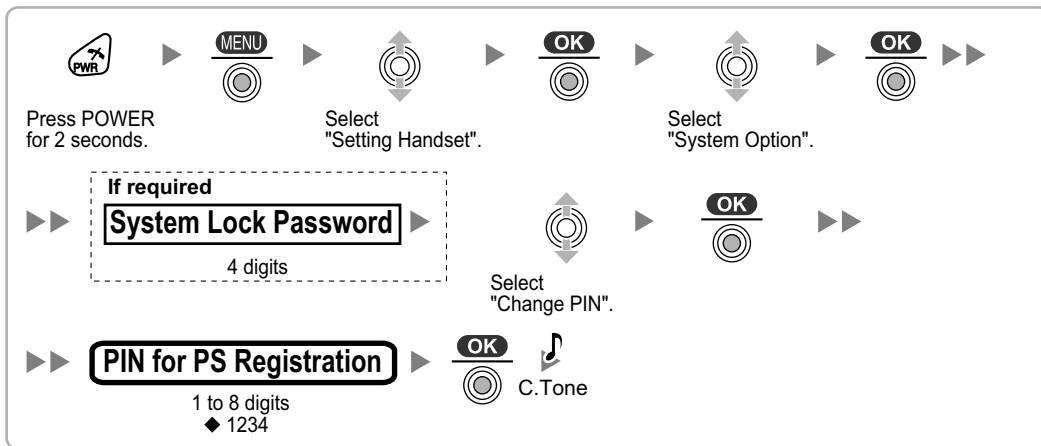

**PS Registration**

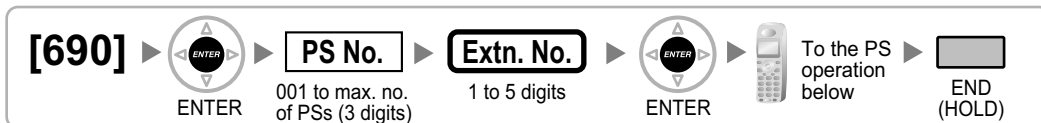

**When the PS has not been registered yet**

When registering the PS for the first time, it is possible to select the desired language for the display. (You do not need to enter the PS system programming mode when registering for the first time.)

### Using the KX-TD7685/KX-TD7695/KX-TD7696

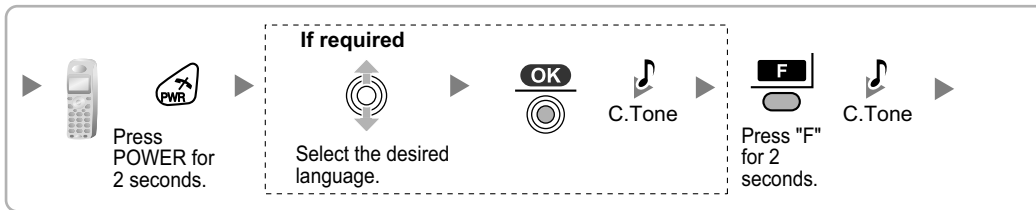

### When the PS has already been registered to another PBX

One PS can be registered to a maximum of 4 different PBXs.

### Using the KX-TD7685/KX-TD7695/KX-TD7696

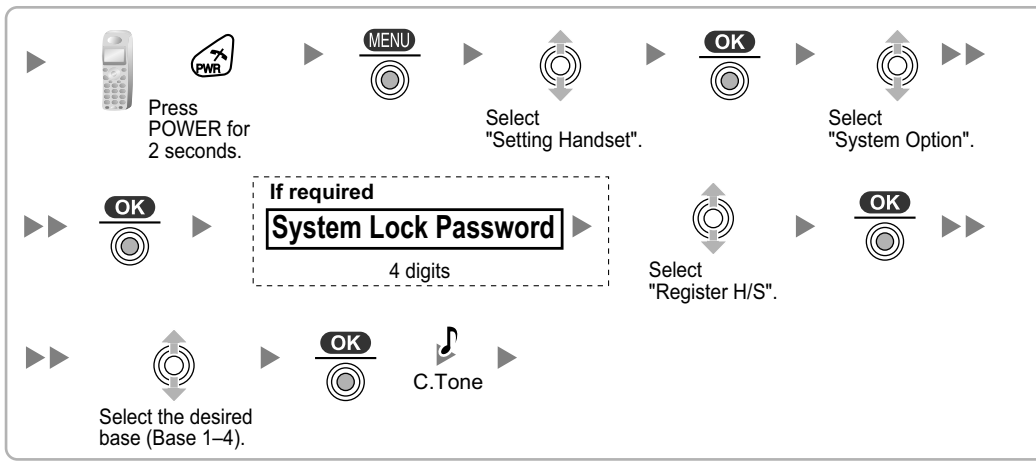

### Setting the System Lock

After PS registration, it is possible to set a 4-digit system lock password to prevent unauthorized access to PS system settings. When system lock is enabled, the system lock password will be required to access PS system settings.

### **CAUTION**

To avoid unauthorized access and possible abuse of the PBX, we strongly recommend:

- a. Keeping the password secret.
- b. Changing your password regularly.
- c. Selecting a complex, random password that cannot be easily guessed.



Using the KX-TD7685/KX-TD7695/KX-TD7696

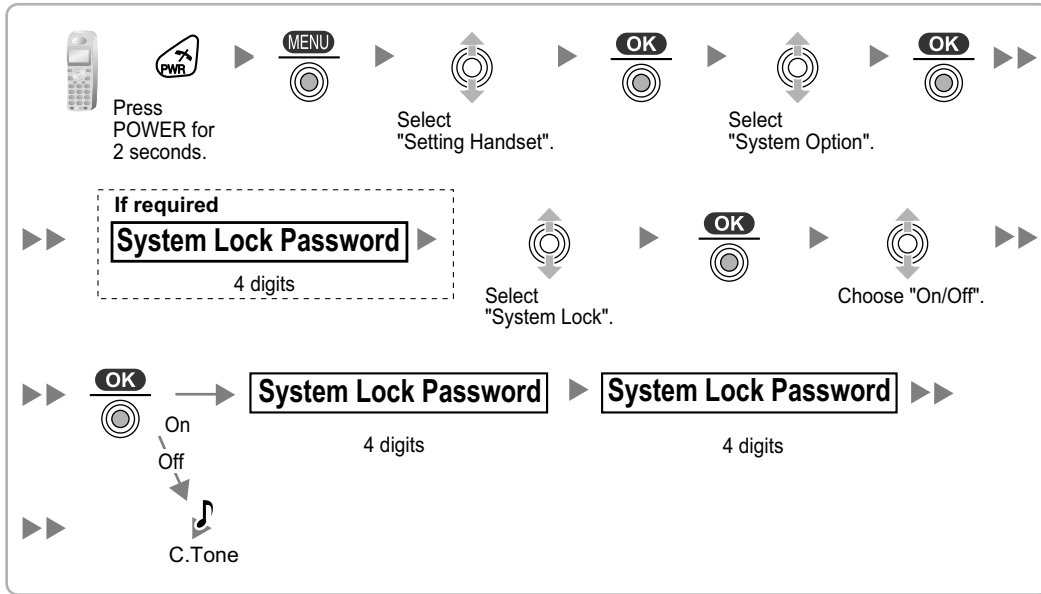

PS Termination

Confirm the following before canceling the PS registration:

- The PS is turned on.
- The PS is within range.

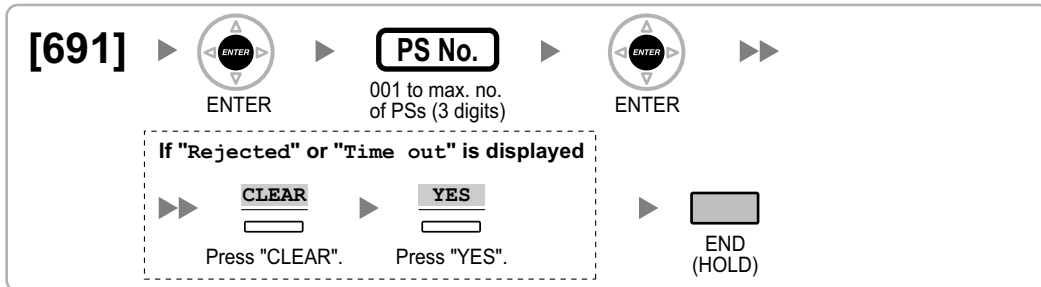

If "Rejected" or "Time out" is displayed

The registration information is still stored in the PS. You need to delete the registration information from the PS.

## Using the KX-TD7685/KX-TD7695/KX-TD7696

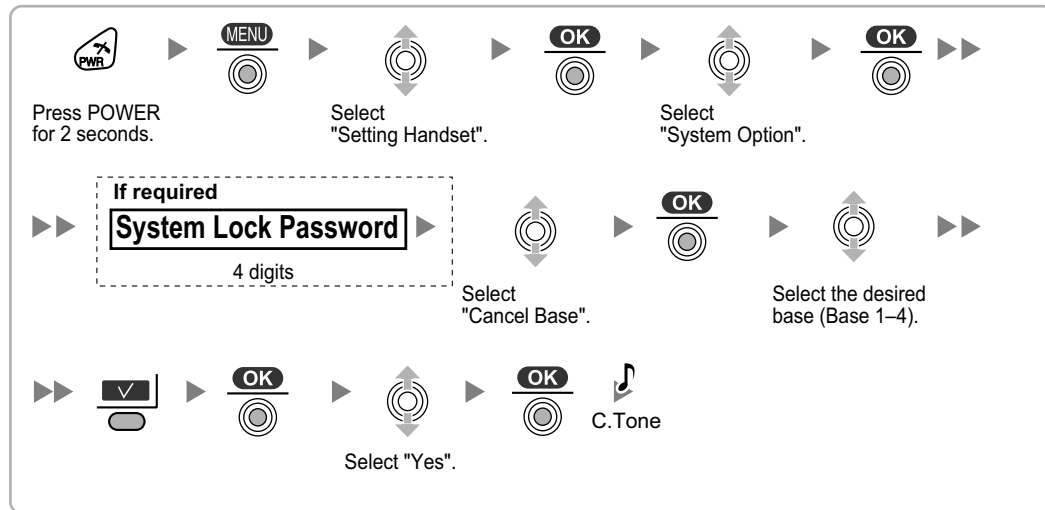

## Testing the Operation

Walk around the service area while having a conversation using a registered PS. If noise is frequent or conversations disconnect, relocate the CSs or install an additional CS.

# 8 Wall Mounting

## Mounting the KX-T0155/KX-T0158/KX-TDA0156

### WARNING

- Make sure that the wall that the unit will be attached to is strong enough to support the unit (approx. 310 g [11 oz]). If not, it is necessary for the wall to be reinforced.
- Only use the wall-mounting equipment (screws, washers, wall mounting plate) included with the unit.
- When this product is no longer in use, make sure to detach it from the wall.

### CAUTION

- When driving the screws into the wall, be careful to avoid touching any metal laths, wire laths or metal plates in the wall.
  - Do not stretch or bend the cables. Also, do not allow anything to rest on the cables.
  - Use cables that are fire-resistant or fireproof.
  - The CS and the cables should never be placed near or over a radiator or other heat source.
  - Do not bundle cables that are connected to the CS with the AC power cords of machines located nearby.
  - Make sure the cables are securely fastened to the wall.
1. Place the reference for wall mounting on the wall to mark the 2 screw positions.
  2. Install the 2 screws and washers (included) into the wall.

### Note

- Make sure that the screw heads are at the same distance from the wall.
  - Install the screws perpendicular to the wall.
3. Insert the upper and lower tabs of the wall mounting plate into the designated openings in the base unit.

**KX-T0155/KX-TDA0156**

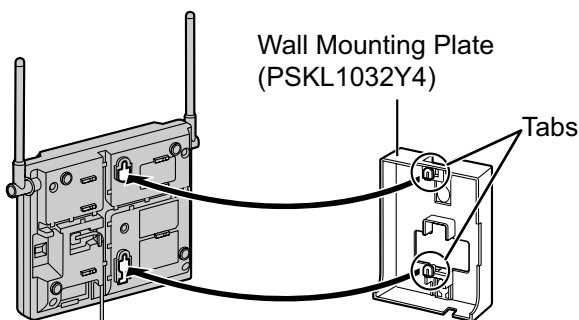

**KX-T0158**

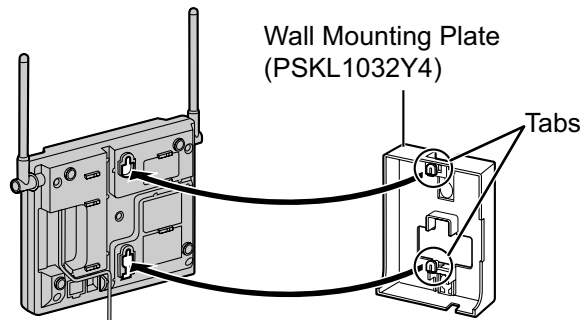

4. Slide the wall mounting plate in the direction of the arrow until it clicks.

KX-T0155/KX-TDA0156

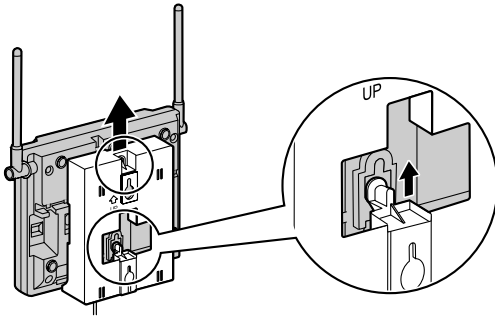

KX-T0158

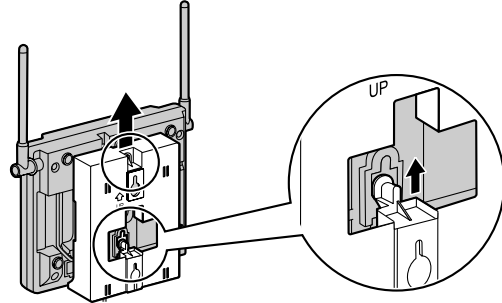

5. Hook the CS on the screw heads.

KX-T0155/KX-TDA0156

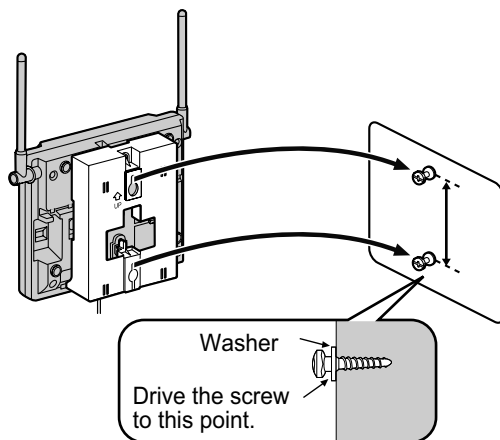

KX-T0158

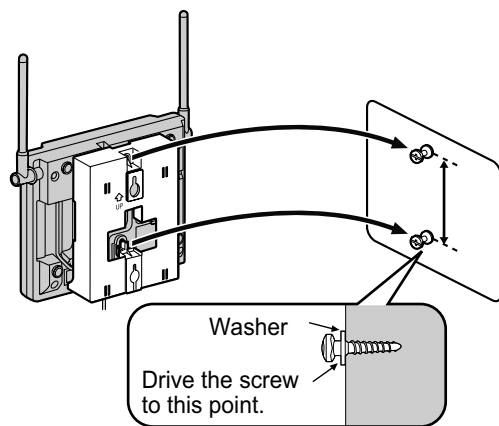

6. Place the antennas so that they are pointing in directions that are 90 degrees apart (for antenna diversity), as follows:

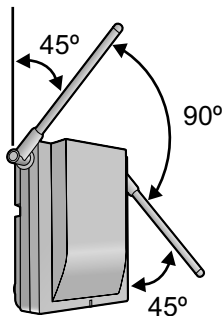

## Reference for Wall Mounting

Please copy this page and use as a reference for wall mounting.

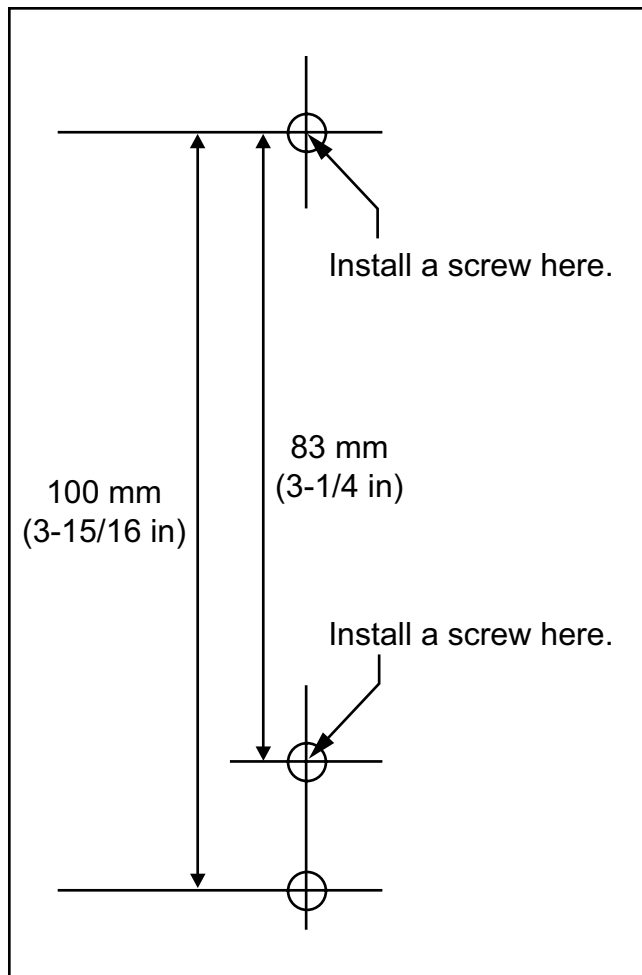

### Note

Make sure to set the print size to correspond with the size of this page. If the dimension of the paper output still deviates slightly from the measurement indicated here, use the measurement indicated here.

## 9 Troubleshooting

PROBLEM	PROBABLE CAUSE	SOLUTION
<ul style="list-style-type: none"> <li>The LED of the CS does not change to Green ON.</li> </ul>	<ul style="list-style-type: none"> <li>The optional service card is not working.</li> </ul>	<ul style="list-style-type: none"> <li>Install the card properly.</li> </ul>
	<ul style="list-style-type: none"> <li>CS is not connected properly.</li> </ul>	<ul style="list-style-type: none"> <li>Make sure that the cable is connected properly with correct pin assignments. Also, make sure that the cable does not make short circuits.</li> </ul>
	<ul style="list-style-type: none"> <li>CS is not set for normal operation.</li> </ul>	<ul style="list-style-type: none"> <li>Switch all DIP switches off.</li> </ul>
	<ul style="list-style-type: none"> <li>The status of the port that the CS is connected to is Out of Service.</li> </ul>	<ul style="list-style-type: none"> <li>Change the port status from Out of Service to In Service using the Maintenance Console.</li> </ul>
	<p>&lt;Only when connecting a KX-T0158 CS to a KX-TDA600/KX-TDE100/KX-TDE200/KX-TDE600&gt;</p> <ul style="list-style-type: none"> <li>The Local Processor (LPR) software of the corresponding DHLC/DLC card is not version 5.000 or later.</li> </ul>	<ul style="list-style-type: none"> <li>Upgrade the LPR software of the DHLC/DLC card.</li> </ul>
<p>&lt;KX-T0158 only&gt;</p> <ul style="list-style-type: none"> <li>Both KX-T0158 and KX-T0155 CSs are connected to the same card, and the KX-T0158 CSs are connected to higher-numbered pins on the card than the KX-T0155 CSs.</li> </ul>	<ul style="list-style-type: none"> <li>Connect the KX-T0158 CSs to lower-numbered pins on the card than the KX-T0155 CSs.</li> <li>Connect the KX-T0158 and KX-T0155 CSs to different cards.</li> </ul>	
<p>&lt;KX-T0158 only&gt;</p> <ul style="list-style-type: none"> <li>The maximum number of PS calls that the CS supports cannot be made.</li> </ul>	<ul style="list-style-type: none"> <li>Poor connection</li> </ul>	<ul style="list-style-type: none"> <li>Make sure that a 4-pair cable is used for connection.</li> </ul>
<ul style="list-style-type: none"> <li>The LED of the CS stays Red ON during normal operation.</li> </ul>	<ul style="list-style-type: none"> <li>CS malfunction</li> </ul>	<ul style="list-style-type: none"> <li>Replace the CS.</li> </ul>
<ul style="list-style-type: none"> <li>"CLEAR SCAN DATA" is displayed on the PS's screen after turning on the PS.</li> </ul>	<ul style="list-style-type: none"> <li>The PS cannot be used for normal operation when scan data is stored on the PS.</li> </ul>	<ul style="list-style-type: none"> <li>Clear the scan data by following the procedure described in "Clearing the Stored Scan Data" in this guide.</li> </ul>

PROBLEM	PROBABLE CAUSE	SOLUTION
<ul style="list-style-type: none"> <li>Cannot register the PS.</li> </ul>	<ul style="list-style-type: none"> <li>Wrong Personal Identification Number (PIN) is registered to the PS.</li> </ul>	<ul style="list-style-type: none"> <li>Enter the PIN set to the PBX into the PS.</li> </ul>
<ul style="list-style-type: none"> <li>PS becomes out of range.</li> <li>Cannot make calls using the PS.</li> </ul>	<ul style="list-style-type: none"> <li>Location of CS is not good.</li> <li>Access system of the PS is not properly set.</li> </ul>	<ul style="list-style-type: none"> <li>Locate the CS properly (refer to "5 Site Survey").</li> <li>Change the access system setting of the PS to the appropriate system or automatic.</li> </ul>
<ul style="list-style-type: none"> <li>Noise is frequent while using the PS.</li> <li>Conversations disconnect while using the PS.</li> <li>"NO SERVICE" is displayed on the PS's screen.</li> </ul>	<ul style="list-style-type: none"> <li>Call handover is not working.</li> <li>PS is out of CS coverage area.</li> </ul>	<ul style="list-style-type: none"> <li>Locate the CS properly (refer to "5 Site Survey").</li> </ul>
<ul style="list-style-type: none"> <li>The CS is not busy (i.e., the status of the LED is not Moderate Green Flashing), but calls cannot be made or received.</li> <li>There is noise during a phone call.</li> </ul>	<ul style="list-style-type: none"> <li>CSs are located too close together in the same area.</li> </ul>	<ul style="list-style-type: none"> <li>Reduce the number of CSs in the area, or increase the distance between CSs (refer to "5 Site Survey").</li> </ul>
<ul style="list-style-type: none"> <li>PS stays out of service when the CS status is changed from Out of Service to In Service.</li> </ul>	<ul style="list-style-type: none"> <li>It may take about 20 s for the CS to start up after the status has been changed to In Service.</li> </ul>	<ul style="list-style-type: none"> <li>Wait until the CS starts up.</li> </ul>





Panasonic Corporation of North America  
One Panasonic Way, Secaucus, New Jersey 07094

<http://www.panasonic.com/csd>

**Copyright:**

This material is copyrighted by Panasonic System Networks Co., Ltd., and may be reproduced for internal use only. All other reproduction, in whole or in part, is prohibited without the written consent of Panasonic System Networks Co., Ltd.

© Panasonic System Networks Co., Ltd. 2009